

# ROBUST CONTROLLER FOR DAMPING POWER SYSTEM OSCILLATIONS

S.VADIVEL  
P.G.Scholar  
Power systems  
Govt. College of Technology  
Coimbatore-13  
INDIA

J.LAKSHMANAPERUMAL  
Assistant Professor  
Electrical Engineering  
Govt. College of Technology  
Coimbatore-13  
INDIA

**Abstract:** Design of power system stabilizer using Linear Quadratic Regulator (LQR) technique. Designs that ignore noise in a plant are likely to fail when implemented in actual conditions. Presence of the noise, which results in LQR output oscillating with very small magnitude. This type of unwanted noisy output is eliminated using Linear Quadratic Gaussian (LQG) Regulator. This paper presents techniques for the design of power system stabilizer using LQG regulator comprises the Kalman estimator, which is obtained from the optimal state feedback gain designed with LQR. The LQG regulator minimizes the some quadratic cost function that trades off regulation performance and control effort. This indicates that the LQG compensated system is more robust with respect to noise than the LQR with same regulator gain matrix.

**Keywords:** LQR, LQG, Robustness, Performance index, Regulator gain matrix.

## I. INTRODUCTION

We propose in this paper a method for designing a robust controller, including a voltage regulator and a power system stabilizer. This problem is considered as a whole, hence obtained AVR and PSS coordinated.

Damping the electro-mechanical oscillation is very important for network stability, and this topic has been receiving a lot of attention for many years. For all admissible operating points, an action on the excitation voltage has to

- ensure system stability,
- damp the electromechanical oscillation,
- achieve voltage regulation without static error,

- provide good performances in case of short-circuits, switching operations and bus frequency variations.

The latter variation model one kind of interactions between the machine under considerations and other ones. For all machines of the same type, we make the same tuning of the controller parameter; this is very particular mono-machine approach is efficient to solve the multimachine problem.

Once of the difficulties of this problem is due to the different kinds of disturbances neglected. Another difficulty is to obtain good performances for all operating points. As a matter of fact, the behavior of an alternator connected to network depends, among other things, on its position in this network, on the

operating conditions (in particular, on the reactive power flow and on the voltage map), on the network topology and the generation schedule. Therefore, a voltage controller must not be sensitive to changes of operating points. These changes are considered as parametric uncertainties.

Various methods are used to improve and design of power system stabilizers. In most of them, stabilizing signals added to the voltage loop to improve oscillation damping. PSS is designed pole placement technique [7], modern control theory Lyapunov's Approach [4] and LQ theory [10-12]. Unfortunately these approaches are not well suited for designing a robust controller with respect to parametric uncertainties. LQG technique is more robust against parametric uncertainties.

A generator is connected to an infinite bus is a nonlinear system, which can be linearized around the operating point defined by specific values  $P^*$ ,  $V^*$ ,  $Q^*$ , and  $X^*$  of the active power, of the terminal

voltage, of the reactive power and of the external reactance. Hence, the linearized model depends on the vector of parameters  $\Theta^*=[P^*, V^*, Q^*, X^*]^T$ .  $\Theta^*$  can vary in one domain D, called << admissible parametric domain >> which characterizes all the possible operating points. Some of the components of  $\Theta^*$  (especially  $X^*$ ) are unknown. Moreover, in order to obtain a constant linear controller, it is assumed in this paper that the whole vector  $\Theta^* \in D$  is unknown (whereas D is known). The variations of  $\Theta^*$  in D are the parametric uncertainties.

The aim of this paper is to propose a method for designing a robust controller with respect to these parametric uncertainties. More specifically, this controller is linear, independent of  $\Theta$  and for every  $\Theta \in D$

- provides sufficient robustness margins(i.e. gain, phase and delay margins)
- minimizes the effects of disturbances on the machine terminal voltage.

The organization of this paper is as follows: in section II we briefly review the linearized power system model. In section III the formulation of PSS designed by LQR is presented. In section IV the proposed method of PSS designed by LQG Regulator. In section V the time domain simulations for stability studies of the proposed controllers are shown.

## II. POWER SYSTEM MODEL FOR STABILITY STUDY

Block diagram of the linearized power system model [1] shown in fig.1

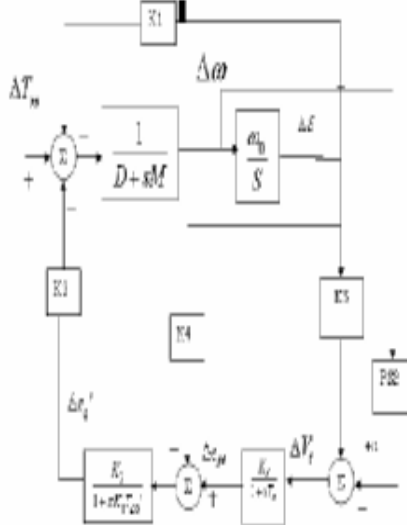

Fig.1 Linearized power system model model

The linearized differential equations of a single-machine, infinite bus system are expressed as follows

$$\Delta E'_q = \frac{1}{K3T'_{d0}} \Delta E'_q - \frac{k4}{T'_{d0}} \Delta \delta + \frac{1}{T'_{d0}} \Delta E'_{fd} \quad (1)$$

$$\Delta \delta' = \omega s \Delta v \quad (2)$$

$$\Delta v' = -\frac{k2}{2H} \Delta E'_q - \frac{K1}{2H} \Delta \delta - \frac{D\omega s}{2H} \Delta v + \frac{1}{2H} \Delta T_m \quad (3)$$

$$\Delta E'_{fd} = -\frac{1}{TA} \Delta E'_{fd} - \frac{KAk5}{TA} \Delta \delta - \frac{KAk6}{TA} \Delta E'_q + \frac{KA}{TA} \Delta V_{ref} \quad (4)$$

The all over state space model for fig.1 becomes  $x^{(1)} = Ax + Bu$  (5)

$$y = Cx \quad (6)$$

$$A = \begin{bmatrix} \frac{1}{K3T'_{d0}} & -\frac{k4}{T'_{d0}} & 0 & \frac{1}{T'_{d0}} \\ 0 & 0 & \omega s & 0 \\ -\frac{k2}{2H} & -\frac{K1}{2H} & -\frac{D\omega s}{2H} & 0 \\ -\frac{KAk6}{TA} & -\frac{KAk5}{TA} & 0 & -\frac{1}{TA} \end{bmatrix}$$

$$B = \begin{bmatrix} 0 \\ 0 \\ 0 \\ \frac{KA}{TA} \end{bmatrix}$$

## III. PSS DESIGN USING LQR

The Power system stabilizer is designed using LQR. The LQR design is a method of reducing the performance index to a optimal value, so as to achieve optimal performance of the system.

The performance index J is given by

$$J(t, t_f) = \int_t^{t_f} [X^T(\tau)Q(\tau)x(\tau) + u^T(\tau)R(\tau)u(\tau)]d\tau \quad (7)$$

where,

Q is a positive-definite (or positive-semi-definite) Hermitian or real symmetric matrix.

R is a positive-definite Hermitian or real symmetric matrix.

The state feedback gain matrix K will then modify the control signal U and LQR control signal will have the form

$$U=Kx \quad (8)$$

The design of LQR depends upon the Q and R matrices. The two matrices Q (an n x n matrix) and R (an m x m matrix) are selected by our choice. By selecting Q large means that, to keep J small, the state x (t) must be smaller. On the other hand selecting R large means that the control input must be smaller to keep J small. This meant that larger values of Q generally result in the poles of the closed loop system matrix  $A_C = (A-BK)$  being further left in the s-plane so that the state decays faster to zero. On other hand, larger R means that less control effort is used, so that the poles are generally slower, resulting in larger values of the x (t).

#### IV. PSS DESIGN USING LQG REGULATOR

As was said above, the difficulty of our problem principally lies in parameter uncertainties. We have to ensure system stability as well as good performance when the system parameters vary. LQG method, separation principle includes parameter uncertainties at the design of power system stabilizer.

Consider a general state equation of a linear model,

$$\dot{x}^{(1)} = A(t)x(t) + B(t)u(t) + F(t)v(t) \quad (9)$$

$$y(t) = C(t)x(t) + D(t)u(t) + z(t) \quad (10)$$

where  $v(t)$  is the process noise vector which may arise due to modeling errors such neglecting nonlinear or higher-frequency dynamics, and z (t) is the measurement noise vector. By assuming  $v(t)$  and z (t) to be white noise.

This type of regulator forms the Linear Quadratic Gaussian Reulator connecting the Kalman estimator designed with Kalman and optimal state-feedback gain designed with Linear Quadratic Regulator. The LQG regulator minimizes some quadratic cost function that trades off regulation performance and control effort.

The optimal compensator design process is the following:

- (1) Design an optimal regulator for a linear plant assuming full-state feedback (i.e. assuming all the state variables are available for the measurement) and a quadratic objective function (such as that given by Eq. (7)). The regulator is designed to generate a control input, u(t), based upon the measured state-vector, x(t).
- (2) Design the Kalman filter for the plant a known control input, u(t), a measured output, y(t), and white noises, v(t) and z(t), with known power spectral densities. The Kalman filter is designed to provide an optimal estimate of the state-vector,  $x_0(t)$ .
- (3) Combine the separately designed optimal regulator and Kalman filter into an optimal compensator, which generates the input vector, u(t), based upon the estimated state-vector,  $x_0(t)$ , and the measured output vector, y(t).

Since the optimal regulator and Kalman filter are designed separately, they can be selected to have desirable properties that are independent of one another. The closed loop eigen values consist of the regulator eigen values and Kalman filter eigen values. The closed-loop system's performances can be obtained as desired by suitably selecting the optimal regulator's weighting matrices, Q, R, and the Kalman filter's spectral noise densities, v, z, and  $\Psi$ . Hence, the matrices Q, R, v, and  $\Psi$  are the design parameters for the closed-loop system with optimal compensator.

A state-space realization of the optimal compensator for regulating a noisy plant with state-space representation of Eq.9 and Eq.10 becomes

$$x_0^{(i)}(t) = (A - BK - LC + LDK)x_0(t) + Ly(t) \quad (11)$$

$$u(t) = -Kx_0(t) \quad (12)$$

where K and L are the optimal regulator and Kalman filter gain matrices respectively. MATLAB command lqe, lqreg are used in m file.

## V. SIMULATION RESULTS FOR STABILITY STUDY

In this section, the performance tests for a small-signal stability study are done in a simple power system, where the single machine is connected to an infinite bus, and are carried out to evaluate the performance of the proposed robust controller.

Power system stabilizer designed by LQR used to damping oscillations caused by large disturbances and can effective in restoring normal steady state condition. This type of power system stabilizer is to reduce the transient time and settling time, the figure 1, 2 and 3 shows the stabilized response of voltage, accelerating power and angular velocity respectively.

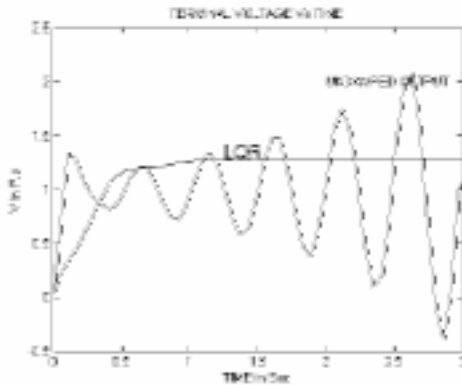

Fig.1 Stabilized response of the voltage using LQR

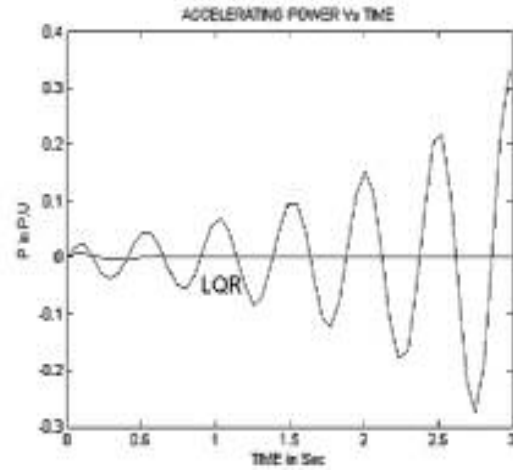

Fig.2 Stabilized response of the Accelerating power using LQR

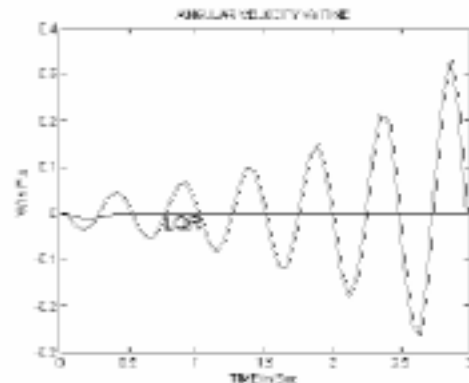

Fig.3 Stabilized response of the angular velocity using LQR

Presence of the noise in the system affects output of the Linear Quadratic Regulator with small oscillating magnitude figure 4 shows the noisy output of the Linear Quadratic Regulator.

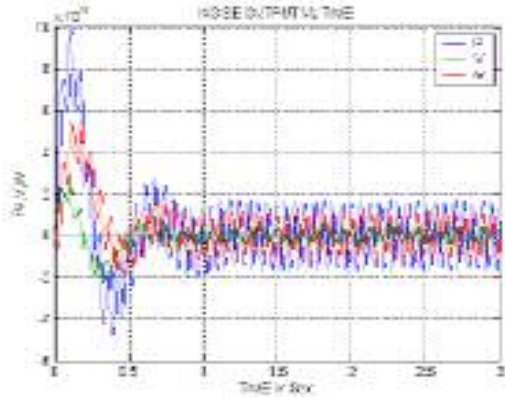

Fig. 4 LQR Output with Noise

The proposed power system stabilizer designed using Linear Quadratic Gaussian Regulator is efficient to damp out the oscillations caused by large disturbances and to restore the normal steady state condition. Figure 5, 6 and 7 shows that the output of the LQG Regulator with the oscillatory response of the voltage, accelerating power and angular velocity of the unstable system, which results LQG Regulator gives the better robustness against system uncertainties.

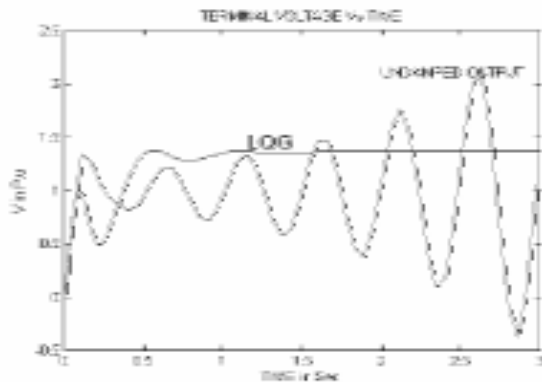

Fig.5 Stabilized response of the voltage using LQG Regulator

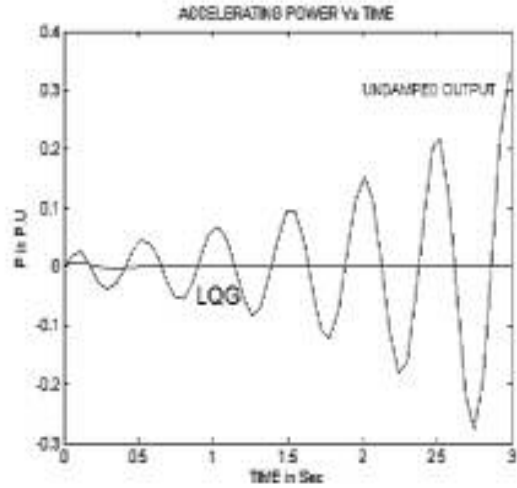

Fig.6 Stabilized response of the Accelerating Power using LQG Regulator

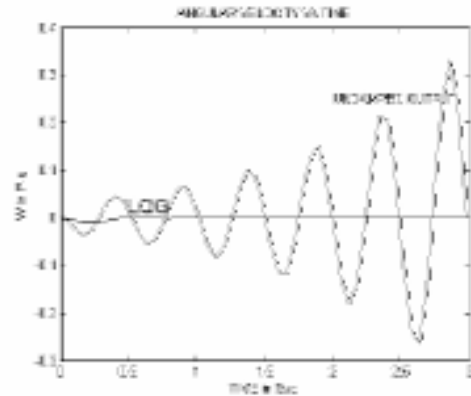

Fig.7 Stabilized response of the Angular velocity using LQG Regulator

The performance of the Linear Quadratic Gaussian Regulator is compared with the Linear Quadratic Regulator and it is found that Linear Quadratic Gaussian Regulator gives the better robustness against system uncertainties. Figure 8, 9 and 10 shows the output of the LQR and LQG Regulator

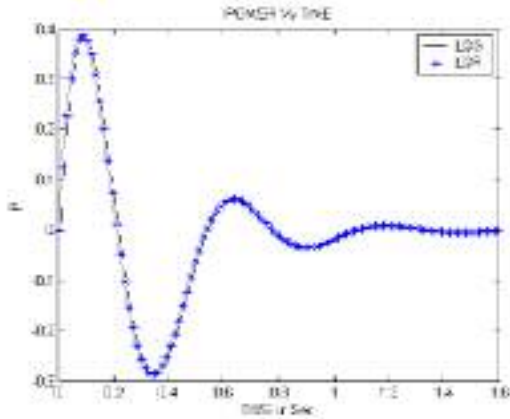

Fig.8 LQR with LQG Output (Accelerating Power)

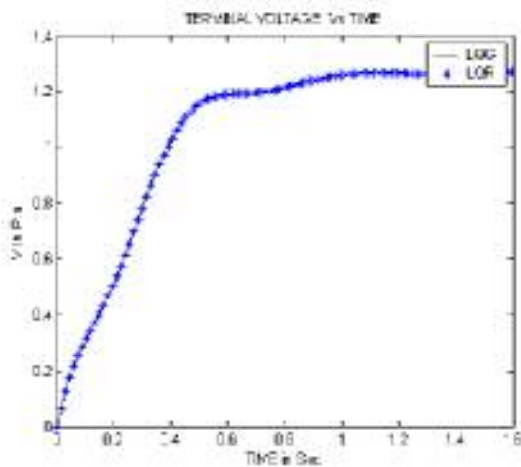

Fig.9 LQR and LQG Output (Voltage)

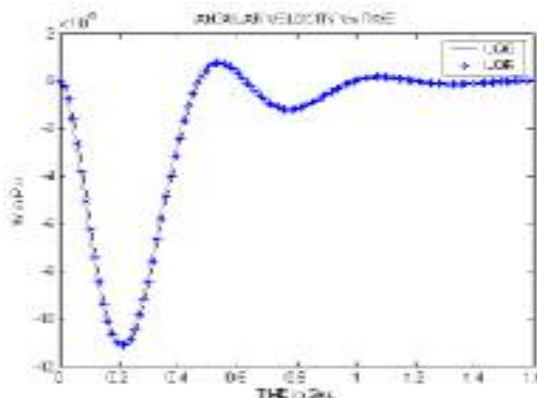

Fig.10 LQR and LQG Output (Angular velocity)

## VI. CONCLUSION

Power system stabilizer has been designed using Linear Quadratic Regulator for single machine connected to infinite system. Linear Quadratic Regulator gives better performances like minimized rise time, steady-state error and settling time. Presence of noise in the system affects output of the Linear Quadratic Regulator with small oscillating magnitude. This unwanted noisy output is eliminated using Linear Quadratic Gaussian Regulator. The performance of the Linear Quadratic Gaussian Regulator is compared with the Linear Quadratic Regulator and it is found that Linear Quadratic Gaussian Regulator gives the better robustness against the system uncertainties.

These methods could be further extended for designing centralized and decentralized controller for multimachine power system.

### References:

- [1] F.P. De Mello, C. Concordia, "Concepts of Synchronous Machine Stability as Affected BY Excitation Control", *IEEE Transactions on Power Apparatus and Systems*, Vol, PAS-88, No.4, pp.316-329, April 1969.
- [2] K.T. Law, D.J. Hill, N.R. Godfrey, "Robust Co-ordinated VR-PSS Design", *IEEE Transactions on Power Systems*, Vol-3, pp.220-232, August 1994.
- [3] K.T. Law, D.J. Hill, N.R. Godfrey, "Robust Controller structure for coordinated Power System Stabilizer Design", *IEEE Transactions on Power Systems*, Vol-9, pp. 1218-1225, August 1994.
- [4] H. Cai, Z. Qu, D. Gan, J.F. Dorsey, "A Robust Power System Stabilizer Design Based on Lyapunov's Approach", *IEEE Transactions on Power Systems, Proceedings of the American control Conference*, pp 1958-1962, June 1997.
- [5] S.S Lee, J.K. Park, and "Design of Power System Stabilizer using Observer/Sliding mode, Observer/Sliding model following and  $H_\infty$ /Sliding mode controllers for small signal stability study", *IEE Transactions On Power and Energy Systems*, Vol-20, No 8, pp 543-553, 1999.

[6]A. Elices, L. Rouco, H. Bourles, and T. Margotin, "Physical Interpretation of State feedback Controller to Damp Power System Oscillations", *IEEE Transactions on Power System*, Vol-19, pp. 436-443, Feb 2004.

[7] E.Irving, P Barret, C. Charcossey, J.P.Monville,"Improving Power Network stability and Unit stress with Adaptive Generator Control"Automatica Vol 15, pp 31-46,1979.

[8]P.M. Anderson, A.A. Fouad, Power System Control and Stability, Iowa State University Press, Iowa, 1977.

[9] P. Kundur, Power System Stability and Control, New York, Mc Graw Hill, 1994.

[10]Peter.W.Saver, M.A. Pai., "Power System Dynamic and Stability", Pearson Education,1998.

[11] Anderson, B.D.O., Moore, J.B., 1989, Optimal control Theory, Englewood Cliffs, Prentice-Hall.

[12] Ogata, K., 1998, "Modern Control Engineering ", Prentice-Hall.