

Some Principal Characteristics of Time-Optimal System Design Algorithm

ALEXANDER ZEMLIAK¹, ANTONIO MICHUA²

¹Department of Physics and Mathematics, ²Department of Electronics

Puebla Autonomous University
Av. San Claudio y 18 Sur, Puebla, 72570
MEXICO

Abstract: - The main step of system design algorithm is the optimization procedure that minimizes the cost function of the design process and determines the optimum values of all system elements. The operations number evaluation for different strategies gives the possibility to select the optimal or quasi-optimal strategy that has the minimal computer time.

From the optimization theory point of view the traditional design strategy can be determined as an optimization of some cost function with constraints. The model of the system is the constraints in that case. The evaluation of operations number for the system design has been done on basis of the general design strategy. More general methodology for the system design was elaborated by means of the optimal control theory approach. In this case the problem of the system design can be formulated as the classical problem of the optimal control for the some functional minimization. In this context the aim of the optimal control is to result each right hand side of the main system of the differential equations to zero for the final time and minimize the total computer time. These equations include the special control functions that are introduced to generalize the total design process. Optimal dependencies of the control functions u_j give the minimum computer design time. The optimal behavior of the control functions is the kernel of the time-optimal design algorithm.

Some properties of an additional acceleration effect of the design process were analyzed. The special selection of the optimization process start point provides the acceleration effect with a great probability. The positions of the optimal switch points of the control vector were found on the basis of the analysis of the special Lyapunov function of the design process by means of the time derivative minimization. The combination of the acceleration effect and the optimal switch points of the control vector serve as the principal ideas to the time-optimal design algorithm construction.

Key Words: - Optimal system design, control theory approach, Lyapunov function.

1 Introduction

The electronic system design by the traditional methodology includes the formulation of the principal equation system, the definition of the number of independent variables K and the number of dependent variables M and some type of optimization procedure use. The principal system of equations for the electronic circuit can be formulated as algebraic or integral-differential system. This system can be interpreted as the relations between independent and dependent variables. From the optimization problem point of view this system can be determined as the system of constraints for the cost function minimization.

On the other hand it is possible to use the idea of general optimization [1] for the electronic system design. On this way the independent variables vector includes arbitrary number of the systems components

from K to $K+M$. In that case the cost function includes additional penalty terms that simulate the relation equations. This approach includes 2^M different design strategies and serves as the source for the time-optimal strategy search.

The reformulation of the optimization process on heuristic level was proposed decades ago [2]. This process was named as generalized optimization and it consists of the Kirchhoff law ignoring for some parts of the system model. The special cost function is minimized instead of the circuit equation solve. This idea was developed in practical aspect for the microwave circuit optimization [3] and for the synthesis of high-performance analog circuits [4] in extremely case, when the total system model was eliminated. This design strategy can be named as the modified traditional design strategy and it is an alternative to de traditional design strategy.

Nevertheless all these ideas can be generalized to reduce the total computer design time for the system design. This generalization can be done on the basis of the control theory approach and includes the special control function to control the design process. This approach consists of the reformulation of the total design problem and generalization of it to obtain a set of different design strategies inside the same optimization procedure [5]. An additional acceleration effect [6] serves as the first principal component of the optimal algorithm construction. The second principle can be defined as the special start point selection [7] for the design algorithm initialization. Nevertheless, the main problem of the time-optimal algorithm construction is the problem of the optimal switch point position search for the control functions switching.

2 Operations Number Evaluation

For the computer time comparison of different kinds of design strategy and for optimal algorithm elaboration it is necessary to evaluate the operations number.

By general design strategy, in case when the number of independent parameters is variable and equal to $K+Z$ the following two systems are used:

$$\frac{dx_i}{dt} = -b \cdot \frac{dF(X)}{dx_i}, \quad j=1,2,\dots,K+Z \quad (1)$$

$$g_j(X) = 0, \quad j=Z+1,Z+2,\dots,M \quad (2)$$

where $F(X) = C(X) + \frac{1}{e} \sum_{j=1}^Z g_j^2(X)$.

In this case the total operations number N for the solution of the systems (1), (2) can be evaluated as:

$$N = L\{K+Z+(1+K+Z)\{C+(P+1)Z+S[(M-Z)^3+(M-Z)^2(1+P)+(M-Z)P]\}\} \quad (3)$$

when the Newton's method is used for the system (2) solution. Formula (3) gives the operations number for the traditional design strategy when $Z=0$ and for the modified traditional design strategy when $Z=M$. Sometimes the necessary operation number C for the cost function $C(X)$ calculation do not has dependency from the independent parameters number $K+Z$, but for the majority of electronic systems is in proportion

to the sum $K+Z$ ($C = c(K+Z)$). Formula (3) in this case is transformed into following expression:

$$N(Z) = L\{K+Z+(1+K+Z)\{c(K+Z)+(P+1)Z+S[(M-Z)^3+(M-Z)^2(1+P)+(M-Z)P]\}\} \quad (4)$$

An analysis of the operations number N as the function of Z by formula (4) gives us the conditions for the minimal computer time. In case when the system (2) is the linear one this general design strategy almost has no preference in computer time as shown in [1]. Formula (4) gives the optimum point Z_{opt} that is within the region $(0, M)$ for the nonlinear system (2).

In more general case, when the system's model can be separate on two parts as linear and nonlinear we have the following systems:

a) nonlinear part is given by

$$g_j(X) = 0 \quad (5)$$

$$j=1,2,\dots,r(M-Y)$$

b) linear part is given by

$$AX = B$$

where $r \in [0,1]$; A and B are matrices of the order $(1-r) \cdot (M-Z)$. For this case the formula for the operations number evaluation has the following form:

$$N(Y,Z) = L\{K+Y+Z+(1+K+Y+Z)\{C+(M+1)Z+[M(1-r)-Z]^3+M(1-r)-Z+(P+1)Y+S\cdot[(M \cdot r - Y)^3+(M \cdot r - Y)^2(P+1)+(M \cdot r - Y)P]\}\} \quad (6)$$

The analysis of this formula shows that for the majority of the practice problems it is correct that the optimum point of the function $N(Y,Z)$ is within the dominion. This case is illustrated in Fig. 1. The optimum point (Y_{opt}, Z_{opt}) minimizes the necessary computer time for the large system design and has dependency from the electronic system size and topology. This optimal point can be fined by the different methods, for example we can use the gradient method, the Newton method or Davidon-Fletcher-Powell (DFP) method.

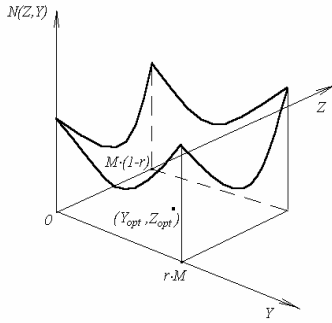

Fig. 1. Behavior of the function $N(Y,Z)$.

The optimization of the space dimension number of independent parameters leads to reduction of the total operation number and therefore to reduction of the total computer time for electronic system design. The analysis of different types of electronic systems shows that the optimal space dimensions of independent parameters can reduce the total computer time to 100 - 500 times. This optimal space dimension has dependency from electronic system size and topology. In this work the problem of optimum order of the space dimension is solved by more general approach on basis of optimal control theory. The total computer time is served as the objective function for the optimal algorithm search.

3 General Formulation

The design process for any analog system design can be defined [5] as the problem of the generalized cost function $F(X,U)$ minimization by means of the vector equation:

$$X^{s+1} = X^s + t_s \cdot H^s \quad (7)$$

with the constraints:

$$(1 - u_j)g_j(X) = 0, \quad (8)$$

$$j = 1, 2, \dots, M$$

where $X \in R^N$, $X = (X', X'')$, $X' \in R^K$ is the vector of independent variables and the vector $X'' \in R^M$ is the vector of dependent variables ($N = K + M$), $g_j(X)$ for all j is the system model, s is the iterations number, t_s is the iteration parameter, $t_s \in R^1$, $H \equiv H(X,U)$ is the direction of the generalized cost function $F(X,U)$ decreasing, U is the vector of the

special control functions $U = (u_1, u_2, \dots, u_m)$, where $u_j \in \Omega$; $\Omega = \{0,1\}$. The generalized objective function $F(X,U)$ is defined as: $F(X,U) = C(X) + \mathbf{y}(X,U)$ where $C(X)$ is the ordinary design process cost function, which achieves all design objects and $\mathbf{y}(X,U)$ is the additional penalty function: $\mathbf{y}(X,U) = \frac{1}{e} \sum_{j=1}^M u_j \cdot g_j^2(X)$. This problem formulation

permits to redistribute the computer time expense between the problem (8) and the optimization procedure (7) for the function $F(X,U)$. The control vector U is the main tool for the redistribution process in this case. Practically an infinite number of the different design strategies are produced because the vector U depends on the optimization current step. The problem of the optimal design strategy search is formulated now as the typical problem for the functional minimization of the control theory. The functional that needs to minimize is the total CPU time T of the design process. This functional depends directly on the operation number and more generally on the design trajectory that has been realized. The main difficulty of this problem definition is unknown optimal dependencies of all control functions u_j . This problem is the central for such type of the design process definition.

4 Design Trajectory Stability

An additional acceleration effect of the design process was discovered [6] on basis of the described methodology, by means of the start point of the vector X variation. This effect appears for all analyzed circuits when at least one coordinate of the start point is negative and gives the possibility to reduce the total computer time additionally. Acceleration effect is produced when the switch is realized from the quasi modified traditional design strategy to quasi traditional strategy [7]. This effect can serve as the basis for the optimal algorithm construction in case when the sequence of the switch points of the control functions u_j is found. So, the main problem to construct the optimal algorithm is the problem of the optimal switch point of the control functions searching during the design process.

To obtain the optimal sequence of the switch points during the design process, we need to define a special criterion that permits to find the optimal control vector U . The problem of the minimal time strategy searching is connected with the more general problem of the stability of each design trajectory. Total design time depends on characteristics of the

design trajectories and first of all depends on the design trajectory convergence. However the convergence is the effect of the design trajectory stability. There is a well known idea to study of any dynamic process stability properties by means of the Lyapunov direct method. We have been defined the system design algorithm as the dynamic controllable process. In this case we can study the stability of each trajectory and the design process transit time properties on the basis of the Lyapunov direct method. We propose now to use a Lyapunov function of the design process for the optimal algorithm structure revelation, in particular for the optimal switch points searching. There is a freedom of the Lyapunov function choice because of a non-unique form of this function. Let us define the Lyapunov function of the design process (7)-(8) by the following expression:

$$V(X) = \sum_i (x_i - a_i)^2 \quad (9)$$

where a_i is the stationary value of the coordinate x_i , in other words the set of all the coefficients a_i is the one of the objectives of the design process. Let us define other variables $y_i = x_i - a_i$. In this case the formula (9) can be rewritten as:

$$V(Y) = \sum_i y_i^2 \quad (10)$$

The design process (7)-(8) can be rewritten by means of the variables y_i in the same form. The function (10) satisfies all of the conditions of the standard Lyapunov function definition. In fact the function $V(Y)$ is the piecewise continue, and has piecewise-continue first partial derivatives. Besides there are three characteristics of this function: i) $V(Y) > 0$, ii) $V(0)=0$, and iii) $V(Y) \rightarrow \infty$ when $\|Y\| \rightarrow \infty$. In this case we can discuss the stability of the zero point solution. On the other hand, the stability of the point (a_1, a_2, \dots, a_N) is analyzed by the definition (9). It is clear that the both problems are identical. Inconvenience of the formula (9) is an unknown point (a_1, a_2, \dots, a_N) , because this point can be reached at the end of the design process only. We can analyze the stability of all different design strategies on the basis of the formula (9) if we already found the design solution somehow. On the other hand, it is very important to control the stability process during the design procedure. In this case we need to

construct other form of the Lyapunov function that doesn't depend on the unknown stationary point. Let us define the Lyapunov function by the next formula:

$$V(X, U) = \sum_i \left(\frac{\partial F(X, U)}{\partial x_i} \right)^2 \quad (11)$$

where $F(X, U)$ is the generalized cost function of the optimization procedure. This function has the same properties as the function (9) for the sufficiently large neighborhood of the stationary point. Really, all derivatives $\partial F / \partial x_i$ are equal to zero in the stationary point $a = (a_1, a_2, \dots, a_N)$, so $V(a, U) = 0$, on the other hand $V(X, U) > 0$ for all X and at last, the function $V(X)$ of the formula (11) is the function of the vector U too, because all coordinates x_i are the functions of the control vector U . The property iii) is not proved only, because nobody know the function $V(X, U)$ behavior when $\|X\| \rightarrow \infty$. However we can consider, from the practical experience, that the function $V(X, U)$ increases in a sufficient large neighborhood of the stationary point. The direct calculation of the Lyapunov function time derivative gives the conditions of the process stability. The design process is stable if the Lyapunov function time derivative is negative. On the other hand, the direct method of Lyapunov gives the sufficient stability conditions but not necessary [8], so the process loses the stability (or not loses) if this derivative becomes positive. The stability of the different design strategies for three-transistor cells amplifier of Fig. 2 was analyzed by the Lyapunov direct method.

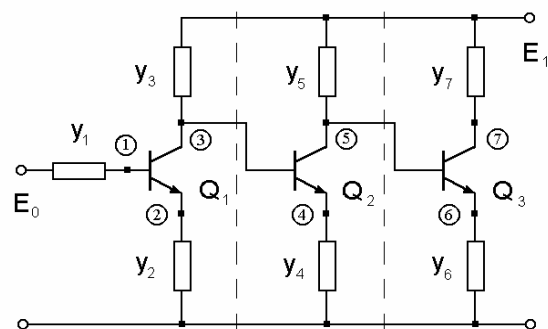

Fig. 2. Circuit topology for three-transistor cell amplifier.

The Lyapunov function time derivative dV/dt is a negative for all trajectories on the initial part of the design process; i.e. all admissible strategies are stable at the beginning. It is supposed that the integration step is sufficiently small. However, when the current point of the trajectory gets to the ϵ -neighborhood of the stationary point a some strategies can lose the stability because the Lyapunov function time derivative becomes positive. It means that all trajectories of this group do not guarantee the convergence from the ϵ -neighborhood. In fact, each of the trajectory of this group has own critical ϵ -neighborhood, which defines the maximum achievable precision. Another consideration is important too: the design process convergence slow down strongly before the ϵ -neighborhood reaching for all strategies of this group. It means that the derivative dV/dt is the negative but very small on the absolute value. It is interesting that the traditional design strategy belongs to this group. The critical ϵ values of some design trajectories for the circuit of the Fig. 2 and two types of the optimization procedure are shown in Table 1.

Table 1. Critical value of the ϵ -neighborhood for some design strategies.

N	Control functions vector $U(u_1, u_2, u_3, u_4, u_5, u_6, u_7)$	Critical epsilon neighborhood	
		Gradient method	DFP method
1	(0 0 0 0 0 0 0)	9.85E-11	9.76E-11
2	(0 0 0 0 0 0 1)	5.92E-06	6.25E-07
3	(1 0 0 0 0 0 0)	9.51E-07	9.35E-07
4	(0 1 1 0 0 0 0)	6.88E-12	5.33E-12
5	(0 1 1 0 1 0 0)	7.55E-15	4.17E-15
6	(1 1 1 1 1 0 1)	3.94E-17	3.53E-17
7	(1 1 1 1 1 1 0)	9.15E-16	6.65E-16
8	(1 1 1 1 1 1 1)	8.15E-17	4.74E-17

Three last strategies have the critical parameter ϵ practically on the boundary of the reachable computer precision. We used the double length words for all numbers during the computing. At the same time these strategies are characterized of the negative values of the derivative dV/dt during the all design process. This property guarantees the process stability. On the other hand, the first five design strategies have the critical ϵ -neighborhood, which depends on the intrinsic properties of the strategy. The derivative dV/dt is not negative when the current point approaches to the critical ϵ -neighborhood for all of these strategies. It results to relative instability and slowing down the design process. We can conclude that all strategies of this group, including the traditional one, have the problem with the

stability when the high precision is needed and therefore the total design time for these strategies is very large. On the other hand there is a group of the strategies (for example 6,7 and 8 of the Table 1) that don't lose the stability until practically any precision. The strategies of this group are characterized a large number of units in the corresponding control vector U and on the contrary, the strategies of the first group are characterized a large number of zeros as shown in Table 1. The time-optimal trajectory consists of the different design strategies in N -dimensional case, but it is very important that it includes strategies with the large number of units in the control vector on its final part. Therefore the time-optimal strategy has a very good stability and that's why this strategy is more rapid than any other is.

Now the function (11) is used for the analysis of the design trajectory behavior with the different switch points. We can define the system design process as a dynamic transition process that provides the stationary point during some time. The problem of the time-optimal design algorithm construction is the problem of the transition process searching with the minimal transition time. There is a well-known idea [8]-[9] to minimize the transition process time by means of the special choice of the right hand part of the principal system of equations, in our case the form of the vector function $H(X,U)$. By this conception it is necessary to change the functions $H(X,U)$ by means of the control vector U selection to obtain the maximum speed of the Lyapunov function decreasing (the maximum of $-dV/dt$) at each point of the process. Unfortunately the direct using of this idea does not serve well for the time-optimal design algorithm construction. It occurs because the change of the design strategy produces not only continuous design trajectories (when we change the strategy $u_j=0, \forall_j$ to the strategy $u_j=1, \forall_j$ for instance) but non-continuous trajectories too (in opposite case). Non-continues trajectories had never been appeared in control theory for the objects that are described by differential equations, but this is the ordinary case for the design process on the basis of the described design theory. In this case we need to correct the idea to maximize $-dV/dt$ at each point of the design process. We define another principle: it is necessary to obtain the maximum speed of the Lyapunov function decreasing for that trajectory part which lies after the switching point. In this case the trajectories with the different switching points are compared to obtain the maximum value of $-dV/dt$. This idea was tested for some nonlinear circuits. The four nodes nonlinear circuit is shown in Fig. 3.

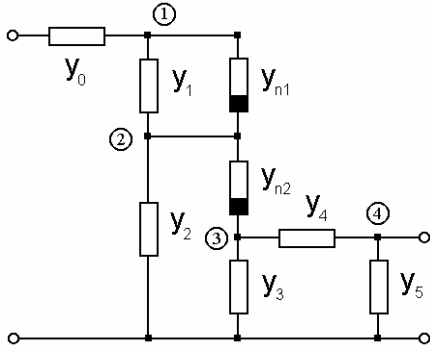

Fig. 3. Four-node circuit topology.

This circuit has five independent variables as admittance y_1, y_2, y_3, y_4, y_5 ($K=5$) and four dependent variables as nodal voltages V_1, V_2, V_3, V_4 ($M=4$). Non-linear circuit elements have the following dependencies: $y_{n1} = a_{n1} + b_{n1} \cdot (V_1 - V_2)^2$, $y_{n2} = a_{n2} + b_{n2} \cdot (V_3 - V_2)^2$. Non-linearity parameters b_{n1}, b_{n2} are equal to 1.0. The numerical results for the above mentioned idea verification, were obtained for this circuit on basis of careful analysis of Lyapunov function time derivative. We need to find the optimal position of the control vector switch point between the modified traditional strategy and the traditional strategy. It is interesting the behavior of the Lyapunov function time derivative as the function of the control vector switch point position. The absolute value of this time derivative increase when the switch point come to the optimal position before it and decrease after the optimal position as shown in Fig. 4. It means that the maximum value of the time derivative serves as the strong criterion for the optimal switch point position determination.

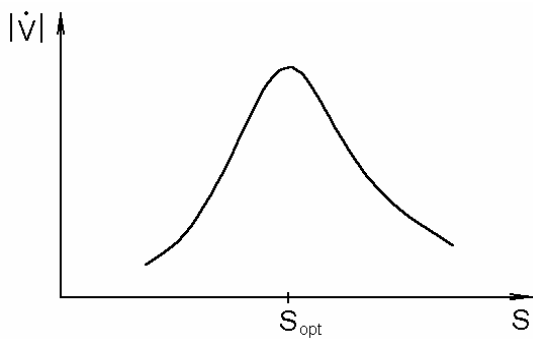

Fig. 4. Absolute value of Lyapunov function time derivative dependency on switch point S.

5 Conclusion

The problem of the time-optimal system design algorithm construction is solved more adequately as the functional optimization problem of the control theory. The main components of the optimal algorithm construction can be defined as: the additional acceleration effect of the system design process; the start point of the design process, which is selected with at least one negative component; and the optimal position of the necessary switch points of control vector that is defined by means of the careful current analysis of the time derivative of the special Lyapunov function of the system design process. These ideas can serve as the basis to the realistic time-optimal design algorithm construction.

Acknowledgment

This work was supported by the Puebla Autonomous University, under project VIEPIII05-04/EXC/G.

References:

- [1] A. Zemliak, General Optimization Procedure for the Electronic Circuits Design, *Proc. 8th Int. Conf. on Electronics, Communication and Computers*, Puebla, Mexico, 1998, pp.225-229.
- [2] I.S. Kashirskiy and Ia.K. Trokhimenko, *General Optimization for Electronic Circuits*, Tekhnika, Kiev, 1979.
- [3] V. Rizzoli, A. Costanzo and C. Cecchetti, Numerical optimization of broadband nonlinear microwave circuits, *IEEE MTT-S Int. Symp.*, Vol. 1, 1990, pp. 335-338.
- [4] E.S. Ochotta, R.A.Rutenbar and L.R. Carley, Synthesis of High-Performance Analog Circuits in ASTRX/OBLX, *IEEE Trans. on CAD*, Vol.15, No. 3, 1996, pp. 273-294.
- [5] A.M. Zemliak, Analog System Design Problem Formulation by Optimum Control Theory, *IEICE Trans. on Fundam.*, Vol. E84-A, No. 8, 2001, pp. 2029-2041.
- [6] A.M. Zemliak, Acceleration Effect of System Design Process, *IEICE Trans. on Fundam.*, Vol. E85-A, No. 7, 2002, pp. 1751-1759.
- [7] A.M. Zemliak, Analysis of the Acceleration Effect of the Analog Circuits Design by the Methods of Control Theory, *Izvestiya VUZ Radioelectr.*, Vol. 47, No. 7, 2004, pp. 52-59.
- [8] E.A. Barbashin, *Introduction to the Stability Theory*, Nauka, Moscow, 1967.
- [9] N. Rouche, P. Habets and M. Laloy, *Stability Theory by Liapunov's Direct Method*, Springer-Verlag, N.Y, 1977.