

Flow Graphs Suitable for Teaching Circuit Analysis

DALIBOR BIOLEK, VIERA BIOLKOVÁ*)
Dept. of Microelectronics *) Radioelectronics
Brno University of Technology
Údolní 53, 602 00 Brno
CZECH REPUBLIC

Abstract: Utilizing the signal flow graphs in teaching linear circuits is discussed in the paper. Some graph features are stated, which should make their inclusion in the existing curriculum easy. The graphs presented seem to be optimum for a quick "hand-and-paper" analysis of circuits containing ideal OpAmps, VCVSs and OTA elements.

Keywords: - Signal Flow Graph, Operational Amplifier, OTA, linear circuit, analysis

1 Introduction

In recent years, the signal flow graphs (SFGs) have faded away from the curricula of a number of faculties of electrical engineering. The reasons can be found in the gradual modification of teaching circuit analysis, which is due to both the wide utilization of computer analysis and simulation, and - above all - the radical innovations of curricula of given fields of study. The matrix methods have come to be preferred in the reduced teaching scope, especially the modified nodal approach (MNA), which has become the universal method of computer simulation.

An important pedagogical aim consists in offering students an effective tool for "hand-and-paper" analysis of relatively small circuits containing active elements such as operational amplifiers (OpAmps). An electrical engineer should be able to solve such common circuits without utilizing a computer and special software. Note that in such cases the SFGs can be of much greater advantage than the MNA. However, this is true on the assumption that the graph method complies at least with the following conditions:

- 1 Simple rules must exist, on the basis of which the student can construct the SFG directly from the schematic without writing any auxiliary equations.
- 2 The graph structure must be economical enough, otherwise the analysis of a relatively simple circuit would lead to a complicated and thus hard-to-evaluate graph.
- 3 Simple rules of graph evaluation must exist, i.e. the extraction of results directly from the graph without any side-computing.
- 4 The graph must enable the evaluation of voltage & current gains and immittances.

Mason's (M) [1], Coates' (C) [2], or Mason-Coates' (M-C) [3] flow graphs belong to the well-known graph techniques. For passive circuits, they match all the conditions above. However, the layout changes significantly when a model of circuit transformation element is not compatible with the admittance equations of the classical MNA. Then a number of published solutions do not conform to rule No. 1 because of the necessity of compiling the circuit equations prior to constructing the graph [3].

Several types of signal flow graph have been developed for circuits containing active elements [4], [5]. Their analysis shows the following:

Rules No. 1 and No. 3 are often in contradiction: The way to an economical graph mostly leads through hard-to-remember rules of thumb [5]. Rule No. 3 is fulfilled automatically if the resulting graph is the M-, the C-, or the MC-graph. Then Mason's well-known general gain formula can be used. Rule No. 4 is not fulfilled for some graphs due to the reduction of some variables as a consequence of applying rule No. 2. However, these variables are necessary, for example, for analyzing immittance relations.

A specially modified method of MC graphs with undirected self-loops is described below. This method seems to be optimum as regards fulfilling the above conditions, intended for quick analysis of both the passive circuits and the active circuits comprising VFAs (Voltage Feedback Amplifiers), VCVSs, and OTAs (Operational Transconductance Amplifiers). The graph description is rather complicated for CCCSs. That is why the classical flow graphs are not suitable for direct analysis of current conveyors (CCs). A special method for CCs analysis, utilizing the so-called T-graphs, is described in [6]. However, its application to the teaching process is controversial.

2 Mason's, Coates', or M-C graph?

Theory distinguishes a number of graphs, the best-known of which are Mason's and Coates' graphs. According to our long experience, the most suitable tool for the hand-and-paper analysis of passive and active circuits is Mason-Coates' (M-C) graph with undirected self-loops. Its basic conception is described in [3]. Let us consider the set of two equations (1), which can be written in the form (2):

$$\begin{aligned} y_{11}V_1 + y_{12}V_2 &= I_1 & y_{11}V_1 &= I_1 - y_{12}V_2 \\ y_{21}V_1 + y_{22}V_2 &= I_2 & y_{22}V_2 &= I_2 - y_{21}V_1 \end{aligned} \quad (2)$$

Then the corresponding M-C graph is in Fig. 1 (a).

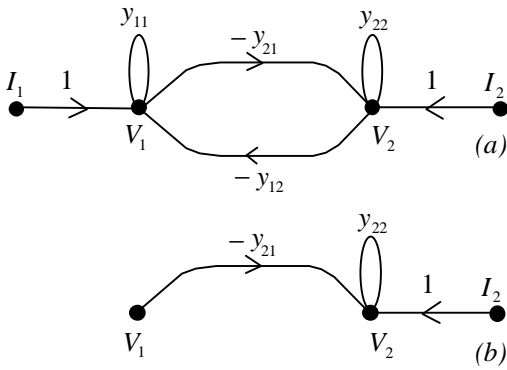

Fig. 1: MC graphs corresponding to the set of equations (1): (a) complete, (b) shortened.

Each of two graph nodes, denoted as V_1 and V_2 , along with the incoming branches, represents one of the set of equations (2).

The evaluation of the M-C graph is done by the well-known procedure described, for example, in [3]. That is why we will not give it here.

3 Complete or shortened M-C graph?

If the set of equations (1) describes an electric circuit excited by source V_1 , whose voltage is known, and if we are not interested in the input current I_1 flowing from this source, then we do not need the first equation in (2) for the analysis. The corresponding operation in the M-C graph consists in reducing the branches and the self-loop according to Fig. 1 (b).

The shortened graph can be of advantage in cases of calculating the voltage gains. A complete graph is necessary, for example, when solving immittance relations.

4 Special modifications of M-C graphs

Let us consider the CCVS (model of OTA in Fig. 2a), the VCVS (model of voltage amplifier in Fig. 2b), and the

ideal OpAmp (OPA, Fig. 2c). A concrete incorporation of these elements into the circuit is considered in Fig. 2. Because of the infinite input resistance of these elements, the equations of Kirchhoff's current law for nodes a and b will not be affected by their inclusion in the circuit. In other words, near these nodes the M-C graph will be of the classical form like for passive circuits. However, the conditions will be changed in the output. Let us consider the following output equations

$$\begin{aligned} Y_c V_c &= I_c + g_m V_a - g_m V_b + \dots, \\ V_c &= A V_a - A V_b, \\ 0 \cdot V_c &= V_a - V_b \end{aligned} \quad (3)$$

for VCVS, VCCS, OPA, respectively.

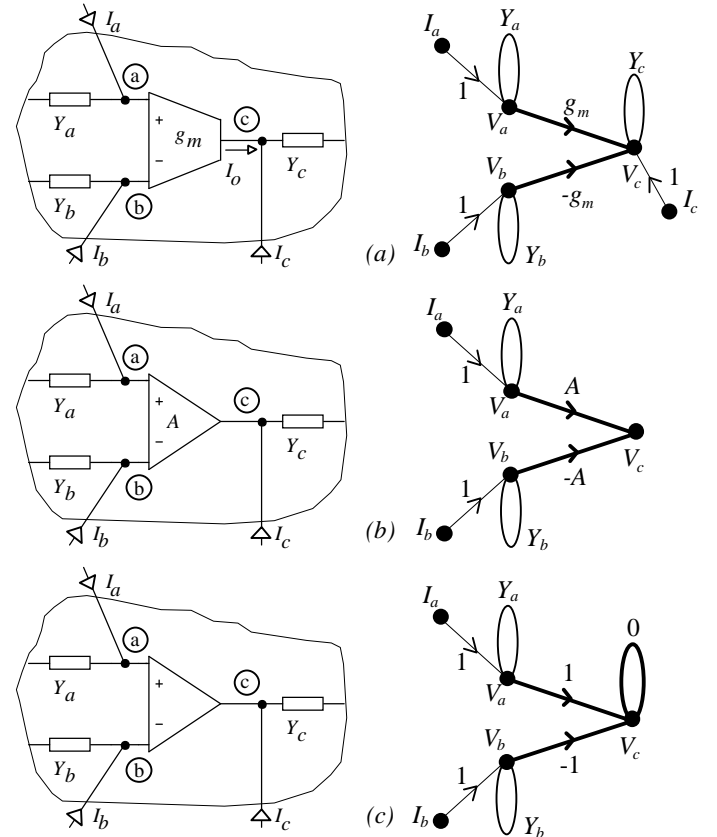

Fig. 2: The OTA (a), ideal voltage amplifier (b) and OPA (c) elements, incorporated in a general circuit, and their corresponding M-C graphs.

Note that only the first equation is the equation of Kirchhoff's current law for node c. The other possible terms, generated by the floating admittance Y_c , are marked by dots. The remaining equations are voltage coupling conditions, which are valid due to the influence of a given active element. They cannot be modified by other elements connected to node c.

The corresponding M-C graphs are also in Fig. 2. The

subgraphs of active elements are emphasized by solid lines.

The following rules of graph construction for circuits with the elements discussed can be summarized as follows:

- An OTA element of transconductance g_m connected between nodes a , b and c according to Fig. 2 (a) will be respected in the graph by two paths directed from node V_a to node V_c and from node V_b to node V_c with path gains of $+g_m$ and $-g_m$.
- An ideal voltage amplifier of gain A connected between nodes a , b and c according to Fig. 2 (b) will be respected in the graph by two paths directed from node V_a to node V_c and from node V_b to node V_c with path gains of $+A$ and $-A$, and by a self-loop in node V_c with a gain of 1 (according to theory this loop need not be drawn [3]). In addition, the following rule must be obeyed: no other path can be directed to node V_c , and the mentioned self-loop gain of node V_c must not be modified.
- An ideal OpAmp connected between nodes a , b and c according to Fig. 2 (c) will be respected in the graph by two paths directed from node V_a to node V_c and from node V_b to node V_c with path gains of $+1$ and -1 , and by a self-loop in node V_c with a gain of 0. In addition, the following rule must be obeyed: no other path can be directed to node V_c , and the mentioned self-loop gain of node V_c must not be modified.

There is no need to know any further rules, except for Mason's general gain formula for graph evaluation. The next example illustrates the analysis procedure.

5 Illustrative example

The schematic of a 2nd-order active filter [7] and the M-C graph constructed according to the above rules are shown in Figs. 3 (a) and 3 (b), respectively. Computing the voltage gain, we make do with the shortened graph.

Evaluating the graph yields the well-known transfer function:

$$\begin{aligned} \frac{V_4}{V_1} &= \frac{-G_1 G_3}{0 + sC_2(sC_1 + G_1 + G_2 + G_3) + G_2 G_3} = \\ &= -\frac{R_2 / R_1}{s^2 R_2 R_3 C_1 C_2 + sC_2(R_2 + R_3 + R_2 R_3 / R_1) + 1} \end{aligned}$$

6 Conclusion

The signal flow graphs described seem to be useful for teaching purposes as a tool of quick solution of simple circuits comprising voltage amplifiers, OpAmps and OTA elements. To construct the graph directly from the

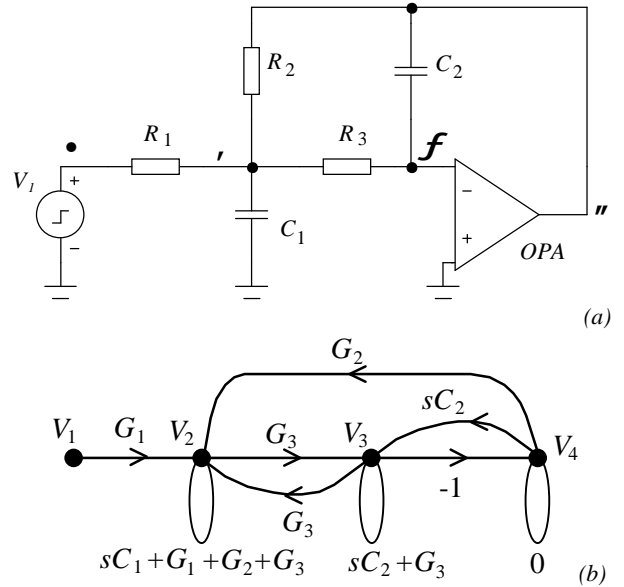

Fig. 3: (a) 2nd-order filter, (b) the corresponding M-C graph.

schematic, student needs to know a minimum number of easy-to-remember rules. The graph is evaluated by Mason's well-known gain formula.

Acknowledgments

This work is supported by the Grant Agency of the Czech Republic under grants No. 102/03/1363 and 102/04/0442, and by the research programmes of BUT MSM 262200022 & MSM 262200011.

References

- [1] Mason, S.J. Feedback Theory: Further Properties of Signal Flow Graphs. Proc. IRE, Vol. 44, No. 7, pp. 920-926, 1956.
- [2] Coates, C.L. Flow-graph Solution of Linear Algebraic Equations. IRE Trans. Circuit Theory, CT-6, pp. 170-187, 1959.
- [3] Čajka, J., Kvasil, J. Linear Circuit Theory. SNTL/ALFA, Prague, 1979 (in Czech).
- [4] Mikula, J. Signal-Flow-Graph-gain with Respect to the General Node of a Graph. Electronics Letters, August 1969, No. 16, pp. 382-383.
- [5] Biolek, D. Solving Electronic Circuits. The book about their analysis. BEN Publisher, Prague, 2004 (in Czech).
- [6] Biolek, D., Biolková, V. Analysis of Circuits Containing Active Elements by using Modified T-graphs. CSCC'01 Int. WSEAS Conference, Crete, Greece, 2001, pp. 4431-4435.
- [7] Schaumann, R., Ghausi, M.S., Laker, K.R. Design of Analog Filters. Prentice Hall, 1990.