

A Particle Swarm approach for the Design of Variable Structure Stabilizer for a Nonlinear Model of SMIB System

NAJI A. AL-MUSABI**, ZAKARIYA M. AL-HAMOUZ*, HUSSAIN N. AL-DUWAISH*

** The Petroleum Institute, Electrical Engineering Program, Abu Dhabi, PO. BOX: 2533
UNITED ARAB EMIRATES, ABU DHABI

* King Fahd University of Petroleum and Minerals, Electrical Engineering Department, Dhahran 31261,

SAUDI ARABIA

Abstract: - There is a vivid trend in engineering optimization problems towards the adoption of heuristic optimization algorithms to arrive at optimal solutions. This is mainly due to the simplicity of these algorithms and the great cut down of complicated mathematical manipulations that are required in other optimization theory methods. This paper demonstrates the application of an iterative heuristic optimization algorithm, namely, Particle Swarm Optimization (PSO), in the design of variable structure stabilizers for a nonlinear single machine infinite bus system (SMIB). Two versions of PSO, namely the inertia weight method of updating the velocities (PSO-iw) and constriction factor method (PSO-cf) are applied in the optimal design of the stabilizer. The success of the PSO approach is supported by simulation results that confirm the attainment of the stabilizer control objectives.

Key-Words: - Variable Structure control, Power system stabilizer, Particle Swarm Optimization

1 Introduction

An important problem in stability of power systems is the excitation control of synchronous machines. The significance of excitation control induced researchers to study and design new control methods for the problem such as Proportional-Integral-Derivative (PID) excitation control, Power System Stabilizers (PSS), Linear Optimal/Sub-Optimal Excitation Control (LOEC), Nonlinear Optimal Excitation Control (NOEC), Adaptive and Intelligent Control [1-5]. In recent years, Power System Stabilizers (PSS) were usually used to enhance the damping of power oscillations caused by several types of small disturbances in a power system. The conventional lead-lag compensation is adopted by most designers due to its simple structure and easy implementation [6]. LQR, Neural Networks, and Fuzzy logic are some of the other design methods proposed for PSS [7-9]. Furthermore, a PSS design based on Variable Structure law is reported in [10-13]. Robustness and good transient response are some of the attractive features of VSC. However, the switching feedback gains of the VSC were not previously chosen by a systematic way. Furthermore, a VSC that operates satisfactory over a wide range of operating point was proposed in [10].ca

However, the feedback gains were again chosen by empirical experiments. In [11], a VS PSS was proposed, for linear model of synchronous machine, which operates over a wide range of operating points by using a neural network to adapt the feedback gains of the controller. For each operating point, the feedback gains were chosen by Genetic Algorithms.

In this paper, a nonlinear model of synchronous machine has been studied and a VSC is designed for it. In conventional design methods, nonlinear transformation techniques are used before linear system theory is applied to the system. The new design method utilizes iterative heuristic optimization techniques (PSO) and provides a simpler and more systematic design.

2 Nonlinear SMIB Model

The nonlinear model of a single machine infinite bus system is shown in Figure 1 [13]. The machine has an AC/DC converter, a silicon-controlled rectifier, for added control purposes. The dynamics of the system are described by the following equations:

$$\dot{\delta} = \omega \quad (1)$$

$$\dot{\omega} = \frac{\omega_b}{2H} [P_m - P_{ac} - KP_{dc}] - D\omega \quad (2)$$

$$P_{dc} = (\cos(\beta) - R_c I_d) I_d \quad (3)$$

$$I_d = 1/L(\cos(\beta) - R_c I_d) \quad (4)$$

$$\dot{P}_m = -\alpha P_m + v \quad (5)$$

Where,

δ : rotor angle of the machine in electrical radians relative to the center of mass.

ω : rotor angular velocity in radians per second with respect to synchronous speed.

H : inertia constant in seconds.

D : damping coefficient in seconds⁻¹.

P_m : per unit mechanical power.

P_{ac} : per unit AC power.

P_{dc} : per unit power stored in the converter.

$\omega_B = 377$ rad/s $K = 1$

α : time constant of governor/turbine or mechanical power actuator

v : the corresponding input

I_d : DC current through converter

R_c : per unit commutating resistance

$X = X_d + X_t + X_l$, $P_{ac} = (E_1 E_2 / X) \sin \delta$.

The dynamic equations can be put into state form by the following definitions:

$x_1 = \delta$, $x_2 = I_d$, $x_3 = \omega$, $x_4 = P_m$. The two control inputs are $u_1 = \cos(\beta)$ and $u_2 = v$.

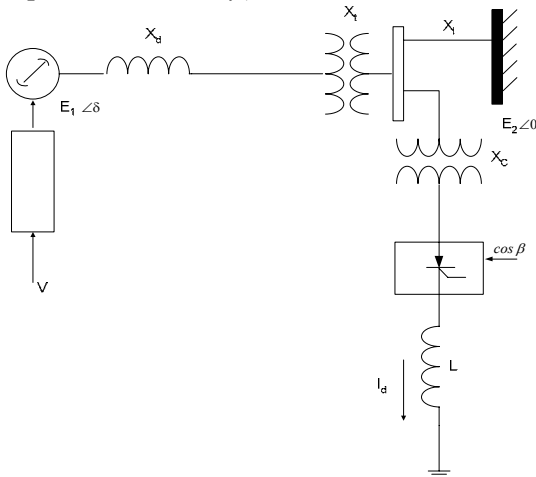

Fig.1 Nonlinear model of SMIB power system

The state space model is given as follows:

$$\begin{bmatrix} \dot{x}_1 \\ \dot{x}_2 \\ \dot{x}_3 \\ \dot{x}_4 \end{bmatrix} = \begin{bmatrix} x_3 \\ -k_1 x_2 \\ -k_2 \sin(x_1) + k_3 x_2^2 - D x_3 + k_5 x_4 \\ -\alpha x_4 \end{bmatrix} + \begin{bmatrix} 0 & 0 \\ k_4 & 0 \\ -k & 0 \\ 0 & 1 \end{bmatrix} \begin{bmatrix} u_1 \\ u_2 \end{bmatrix} \quad (6)$$

Where,

$$k_1 = \frac{R_c}{L}, \quad k_2 = \frac{\omega_B E_1 E_2}{2HX}, \quad k_3 = \frac{\omega_B R_c}{2H}, \quad k_4 = \frac{1}{L}, \quad k_5 = \frac{\omega_B}{2H}$$

The parameters of the system shown in Figure 1 used in this study are [13]: DC converter rated at 80 MW, 230KV system, Machine rating 800 MVA. On a 800 MVA base: $X = 0.2$ p.u., $R_c = 0.3$ p.u., $L = 0.015$ p.u., $H = 7$ s, $D = 0.5$ s⁻¹, and $\alpha = -0.1$ s⁻¹.

This gives: $k_1 = 20$, $k_2 = 177.72857$, $k_3 = 8.078571$, $k_4 = 66.667$, and $k_5 = 26.928571$. The control objective in [13] is to derive the machine from a perturbed state to a desired equilibrium point and maintain it there. This objective involves the following goals: 1) Operating the machine at the rated frequency, i.e. x_3 must be zero at equilibrium 2) keeping the dc current x_2 at zero 3) Delivering a specified amount of AC power to the bus and this defines a *desired load angle* γ of x_1 .

3 Variable Structure Control

The fundamental theory of variable structure systems can be found in [14]. The control law of VSC is a linear state feedback whose coefficients are piecewise constant functions. Consider the linear time-invariant controllable system given by:

$$\dot{X} = AX + BU \quad (7)$$

Where, X is n -dimensional state vector, U is m -dimensional control force vector, A is a $n \times n$ system matrix, and B is $n \times m$ input matrix. The VSC control laws for the system of (7) are given by:

$$u_i = -\psi_i^T X = -\sum_{j=1}^n \psi_{ij} x_j; i = 1, 2, \dots, m \quad (8)$$

Where the feedback gains are given as

$$\psi_{ij} = \begin{cases} \alpha_{ij}, & \text{if } x_j \sigma_i > 0; i = 1, \dots, m \\ -\alpha_{ij}, & \text{if } x_j \sigma_i < 0; j = 1, \dots, n \end{cases}$$

$$\sigma_i(X) = C_i^T X = 0, \quad i = 1, \dots, m$$

C_i are the switching vectors. Some conventional design procedures reported in the literature for selecting the elements of the switching vectors C_i can be found in [15].

4 Particle Swarm Optimization

The Particle swarm optimization (PSO) is an evolutionary computation technique developed by Eberhart and Kennedy [16] inspired by social behaviour of bird flocking or fish schooling. PSO algorithm applied in this study can be described as follows:

Step 1: Initialize a population (array) of particles with random positions and velocities v on d dimension in the problem space. The particles are generated by randomly selecting a value with uniform probability over the d^{th} optimized search space $[x_d^{\min}, x_d^{\max}]$.

Step 2: For each particle x , evaluate the desired optimization fitness function, J , in d variables.

Step 3: Compare particles fitness evaluation with x_{pbest} , which is the particle with best local fitness value. If the current value is better than that of x_{pbest} ,

then set x_{pbest} equal to the current value and x_{pbest} locations equal to the current locations in d -dimensional space.

Step 4: Compare fitness evaluation with population overall previous best. If current value is better than x_{gbest} , the global best fitness value then reset x_{gbest} to the current particle's array index and value.

Step 5: Update the velocity v . There are two ways of updating the velocities and are given below:

a) Inertia weight (PSO-iw):

$$v_{id}(k) = w(k)v_{id}(k-1) + \varphi_1 \cdot rand_1(x_{idpbest}(k-1) - x_{id}(k-1)) + \varphi_2 \cdot rand_2(x_{idgbest}(k-1) - x_{id}(k-1))$$

Where, k is the number of iteration, i is the number of the particles that goes from 1 to n , d is the dimension of the variables, and $rand_{1,2}$ is a uniformly distributed random number in (0, 1), $\varphi_{1,2}$ are acceleration constants and are set, as recommended by investigators [17], equal to 2. The weight w is often decreased linearly from about 0.9 to 0.4 during the search process.

b) Constriction Factor (PSO-cf):

$$v_{id}(k) = K [v_{id}(k-1) + \varphi_1 \cdot rand_1(x_{idpbest}(k-1) - x_{id}(k-1)) + \varphi_2 \cdot rand_2(x_{idgbest}(k-1) - x_{id}(k-1))] K = \frac{2}{|2 - \varphi - \sqrt{\varphi^2 - 4\varphi}|}$$

where $\varphi = \varphi_1 + \varphi_2$, $\varphi > 4$. k , i , d , $rand_{1,2}$, are similar to Inertia weight method. For both methods the particle's velocity in the d^{th} dimension is limited by some maximum value v_d^{max} . This limit further improves the exploration of the problem space. In this study, v_d^{max} is proposed as:

$$v_d^{max} = \eta \cdot x_d^{max}$$

where η is a small constant value chosen by the user, usually between 0.1-0.2 of x_d^{max} [17]. For this study it was found empirically that a value of 0.1 η provides satisfactory results.

Step 6: Update position of the particles,

$$x_{id}(t) = v_{id}(t) + x_{id}(t-1)$$

Step 7: Loop to 2, until a criterion is met, usually a good fitness value or a maximum number of iterations (generations) m is reached.

5 Proposed Design of VS Stabilizer using PSO

In the present work, iterative heuristic PS optimization algorithm is applied in the following way:

Step 1: The control signals, u_1 and u_2 of state space equation (1), are of VSC type and are given as follows:

The states of the system are: $X = [\omega \quad I_d \quad P_{me} \quad \delta_e]$ where,

$$P_{me} = P_m - P_{mdesired} \quad (9)$$

$$\delta_e = \delta - \gamma \quad (10)$$

$$u_1 = -\psi_1 \cdot x_1 \quad (11)$$

$$\psi_1 = \begin{cases} \alpha_1 & \text{if } \sigma_1 \cdot x_1 > 0 \\ -\alpha_1 & \text{if } \sigma_1 \cdot x_1 < 0 \end{cases} \quad (12)$$

$$\sigma_1 = C_1 \cdot x_1 = 0 \quad (13)$$

$$u_2 = -\psi^T \cdot X \quad (14)$$

$$\psi_{2j} = \begin{cases} \alpha_{2j} & \text{if } x_j \sigma_2 > 0 \\ -\alpha_{2j} & \text{if } x_j \sigma_2 < 0 \end{cases} \quad j = 1, \dots, 4 \quad (15)$$

$$\sigma_2 = C_2^T \cdot X = 0 \quad (16)$$

Step 2: The optimum values of the VS stabilizer, which includes C_i and α_{ij} , are found by the PSO algorithm in the following way:

i) Generate random values for feedback gains and switching vector values.

ii) Evaluate a performance index that reflects the objective of the design. In this study the following objective functions are used:

$$J_{ISE} = \int_0^{\infty} \delta_e^2 + P_{me}^2 + \omega^2 + I_d^2 dt \quad (17)$$

$$J_{ITAE} = \int_0^{\infty} t \cdot (|\delta_e| + |P_{me}| + |\omega| + |I_d|) dt \quad (18)$$

Where,

J_{ISE} : Integral of square error objective function and J_{ITAE} : Integral of time multiplied by absolute value of error criterion. By minimizing such objective functions the control objectives will be satisfied.

iii) Use PSO to generate new feedback gains and switching vector values as described in Section 4.

iv) Evaluate the objective functions in Step ii for the new feedback gains and switching vector. Stop if the maximum number of iterations is reached; otherwise go to Step iii.

6 Simulation Results

The system described by equation (6) was simulated with the following initial conditions [13]: $x_1=0.0522$, $x_2=0.1$, $x_3=0.1$, $x_4=6.6\sin(x_1(0))$. The two versions of PSO were used with the following settings:

$k_{max} = 500$ iterations, $n = 20$,

PSO-iw: $w_{min}=0.4$, $w_{max}=0.9$, $\varphi_1 = 2$, $\varphi_2 = 2$,

PSO-cf: $\varphi_1 = 2.1$, $\varphi_2 = 2.1$

The stopping criteria used is to terminate the search process if there is no more improvement in fitness value for the last 100 iterations or if the maximum number of iterations, 500, is reached.

The algorithm has been run for 20 trials since the PSO starts with initial random values. Tables 1 and 2 present the optimal control signals u_1 and u_2 (in terms of switching vector and feedback gain) when using different objective functions. The summary of the performance indices (objective function J and computational time) of the runs for the two objective functions and using the two PSO algorithms when applied to the nonlinear SMIB system is given in Table 3.

Table 1: VSC optimal settings: u_1

	Objective function	C_1	α_1
PSO-iw	J_{ISE}	-1.8720	-3.7974
	J_{ITAE}	-9.8236	-1.9203
PSO-cf	J_{ISE}	-8.5520	-3.7973
	J_{ITAE}	-9.3223	-1.5294

Table 2: VSC optimal settings: u_2

	J	C_2^T
PSO-iw	J_{ISE}	[4.513 4.766 3.538 9.515]
	J_{ITAE}	[2.079 -17.340 1.0756 30.0]
PSO-cf	J_{ISE}	[7.911 15.786 6.7589 13.236]
	J_{ITAE}	[-5.164 -13.165 23.663 -3.835]
	J	α_2^T
PSO-iw	J_{ISE}	[7.8181 1.6952 50.0 -19.0380]
	J_{ITAE}	[50.0 -22.7740 50.0 50.0]
PSO-cf	J_{ISE}	[17.1406 3.841 44.0717 1.0647]
	J_{ITAE}	[-34.6944 19.4223 50.0 50.0]

Table 3: Summary of 20 trials of running PSO for different objective functions

	Objective function	Average value of J	Best value of J	Average Computation time (Mins)
PSO-iw	J_{ISE}	14.592	14.585	9.319
	J_{ITAE}	10.461	10.3856	9.853
PSO-cf	J_{ISE}	14.595	14.586	9.438
	J_{ITAE}	10.709	10.466	8.878

The dynamical behaviour of the SMIB system with the proposed PSO design is shown in Figures 2, 3, and 4.

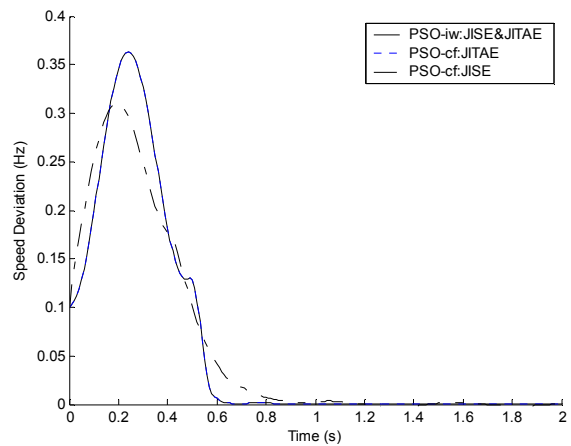

Fig. 2 Frequency deviation

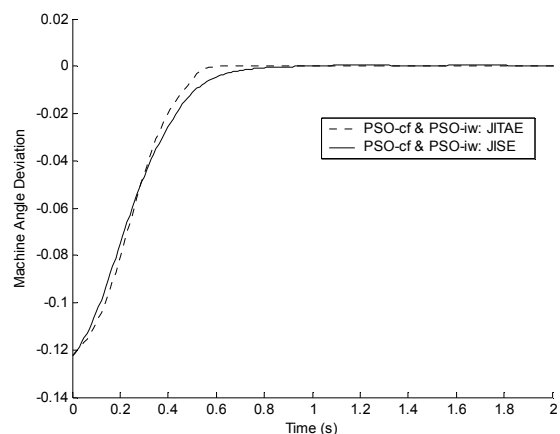

Fig. 3: Deviation of Machine's angle

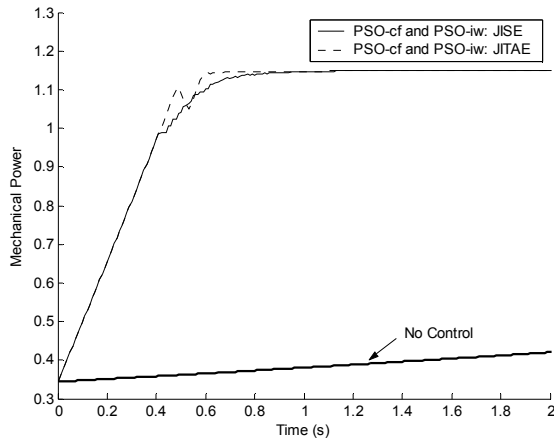

Fig. 4: Mechanical Power

From the obtained results it can be concluded that the proposed design method of VSC can be applied successfully to nonlinear systems. The proposed method requires no nonlinear transformation or linearization of the model. Thus, a systematic simple way of designing VSC controller is achieved. The control objectives of minimizing the frequency deviation and following a desired angle were satisfied. To demonstrate the effectiveness of the present design algorithm, comparison with the results of the design method proposed in [13] has been made. It is quite clear that the dynamical behaviour of the present method is very similar to that of [13] in terms of overshoot and is better in terms of settling time, Tables 4 and 5. On the other hand, the proposed method is much simpler and does not require any nonlinear transformations to arrive at the optimal values for both switching vector and feedback gains.

Table 4: Comparison of Settling time (seconds)

Parameter	[13]	PSO: iw & cf	
		JITAE	JISE
P_m	1	0.6	0.9
ω	0.9	0.7	0.9
Angle	0.95	0.6	0.9

Table 5: Comparison of Overshoot (%)

Parameter	[13]	PSO: iw & cf	
		JITAE	JISE
P_m	2	0	0
ω	30	36	32
Angle	0	0	0

7 Conclusions

- 1) The control objectives of minimizing frequency deviation and following a desired angle, stated in section 2, are all satisfied by the proposed VS-PSO stabilizer, Figures 2 and 3.
- 2) The two versions of PSO showed very similar results with slight out performance of PSO-iw in terms of achieving smaller objective function values, Table 1.
- 3) The ISE objective function reduces slightly the initial overshoot in control terms, Figure2.
- 4) From the reported results it can be concluded that the proposed design of VS stabilizer can be applied successfully to nonlinear systems.

Acknowledgment

The first author would like to acknowledge the support of the Petroleum Institute. The second and third authors would like to thank King Fahd University of Petroleum & Minerals for the support they received.

References

- [1] Y. Y. NU, Title of the Paper, *International Journal of Science and Technology*, Vol.X, No.X, 19XX, pp. XX-XX.
- [1] Y. N. YU, *Electric power system dynamics*, Academic press, 1983.
- [2] Y. H. Song, Emerging techniques for power system dynamics stabilisation, *IEE colloquium on power system dynamics stabilisation*, London, 1998, pp. 12/1-12/5.
- [3] Q. Lu and Y. Sun, *Nonlinear Stabilizing control of multimachine systems*, IEEE Transactions on Power Systems, vol. 4, no.1, 1989, pp. 236-241.
- [4] J. W. Chapman, M. D. Ilic, C. C. King, L. Eng, H. Kanfman, *Stabilizing a multimachine power system via decentralized feedback linearizing excitation control*, IEEE Trans. Power Syst., vol. 8, no. 3, 1993, pp. 830-838.
- [5] X. Y. Li, Y. H. Song, X. C. Liu, J. Y. Liu, *A nonlinear optimal-variable-aim strategy for improving multimachine power system transient stability*, IEE Proceedings- Generation, Transmission, and Distribution, vol. 143, no. 3, 1996, pp. 249-252.
- [6] Y. Z. Sun, X. Li, S. Yan, Y. H. Song, M. M. Farsangi, *Novel Decentralized Robust Excitation control for Power System Stability Improvement*, IEEE International Conference on Electric Utility Deregulation and Restructuring and Power Technologies, 2000, pp. 443-449.

- [7] Q. Lu, Zh. H Wang, Y. D. Ham, *Optimal power system transmission control*, Science publishing house, 1982.
- [8] Y. Hsu and C. Cheng, *Tuning of power system stabilizers using an artificial neural network*, IEEE Transactions on Energy Conversion, vol. 6, 1991, pp. 612-619.
- [9] M. Hassan, O. P. Malik, G. S. Hope, *A fuzzy logic based stabilizer for a synchronous machine*, IEEE Transactions on Energy conversion, vol. 6, no. 3, 1992, pp. 407-413.
- [10] V. Samarasinghe and N. Pahalawaththa, *Damping of multimodal oscillations in power systems using variable structure control techniques*, IEE Proceeding- Generation, Transmission, and Distribution, vol. 144, no. 3, 1997, pp. 323-331.
- [11] H. N. Al-Duwaish and Z. Al-Hamouz, *Adaptive Variable structure controller using neural networks*, conference Record of the 2000 IEEE Industry Applications, vol. 2, 2000, pp. 954-958.
- [12] N. N. Bengiamin and W. C. Chan, *Variable structure control of electric power generation*, IEEE Transactions on Power apparatus and systems, vol. PAS-101, no. 2, 1982, pp.376-380.
- [13] G. P. Matthews, R. A. Decarlo, P. Hawley, S. Lefebvre, *Toward a feasible variable structure control design for a synchronous machine connected to an infinite bus*, IEEE Transactions on Automatic Control, vol. AC-31, no. 12, 1986, pp. 1159-1163.
- [14] Itkis U., *Control Systems of Variable Structure*, Keter Publishing House, Jerusalem, 1976.
- [15] A. Y. Sivarmakrishnan, M. V. Hariharan, and M. C. Srisailam, *Design of variable structure load frequency controller using pole assignment technique*, International Journal of Control, vol. 40, no. 3, 1984, pp. 487-498.
- [16] Kennedy J. and Eberhart R., *Particle Swarm Optimization*, IEEE International Conference on Neural Networks, vol. 4, 1995, pp. 1942-1948.
- [17] R. Eberhat and Y. Shi, *Particle Swarm Optimization: Developments, applications, and resources*, Proceedings of the 2001 Congress on Evolutionary Computation, vol. 1, 2001, pp. 81-86.