

# LED-based Liquid Cryogen Level Measurement

ALI UMIT KESKIN  
CIHAT KOYUNCU

Department of Biomedical Engineering  
Yeditepe University  
TURKEY  
auk@yeditepe.edu.tr

**Abstract:** - A simple liquid sensing and measurement system for determining the level of cryogen in a biomedical dewar container is described. Liquid-gas boundary determination is made by detecting a thermal transient of the series-connected light emitting diodes. An electronic control and display unit located on the outer wall of the container indicates the level of cryogenic liquid, and alarms the operator if it reaches a pre-determined critical level.

**Key-Words:** - Cell preservation, Cryogen, level detection, current conveyor

## 1 Introduction

Cryogenic containers are used in biomedical applications like long term preservation of cells and tissues at temperatures less than 100 K, and they allow for the storage of fluids that are normally gaseous at room temperature. The cryogenic fluid is in two phase state; liquid portion and a gaseous portion. Liquid cryogens can be stored and transported, for example in vacuum flasks. Here, the very low temperature is held constant by slow boiling of the liquid, resulting in the evolution of a cryogen gas. Depending on the size and design, the holding time of vacuum flasks ranges from a few hours to a few weeks.

Various techniques can be used to measure cryogenic liquid levels in such containers. These include thermo-resistive, capacitive, mechanical, electromechanical, optical, weight, and ultrasonic (acoustic) sensors, [1] - [5]. For example, detection based on capacitance is limited by the size of sensors with limited surface area and the need to measure at low voltage levels. They often operate at low detection levels. Dielectric constant of the liquid is a significant factor that influences the effectiveness of the capacitive measurement system. Lower values of dielectric constant (e.g., for liquid Nitrogen, Hydrogen) may yield poor results for small size containers. For example, there is less than 10% difference between dielectric constant of gaseous and liquid hydrogen. This small difference makes it difficult for the capacitive sensor to measure variations in dielectric constant, accurately. Other parasitic capacitances (such as those of the connecting wires) further reduce the sensitivity of the capacitive sensor.

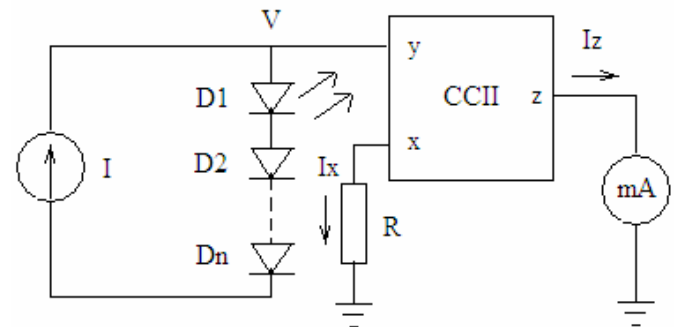

Fig. 1. Principal circuit used for the liquid cryogen level sensing and measurement. Diodes D1,D2,..Dn are LED type, CCII is the current conveyor element, mA is an ammeter, R is the resistor connected to x terminal of CCII.

On the other hand, resistive thermal sensors with either negative or positive temperature coefficients of resistance are available for measurements in a narrow temperature range around room temperature. Generally, such ceramics have lower temperature limits of operation around 200K. This precludes their use at cryogenic temperatures. Si or Ge diodes can be used as

cryogenic temperature sensors [6]-[14]. Although there are reports of using Germanium diodes for liquid level sensors [7], Germanium diodes have relatively small-slope resistance-temperature curves at cryogenic temperatures. Therefore, they are good for cryogenic temperature measurement rather than two phase level sensing. This paper proposes a simple sensor consisting of a linear array of light emitting diodes and an electronic monitor-display unit to indicate the level of two phase fluid cryogen in a container.

## 2 Sensor Diode selection

The principal for diode thermometry is the temperature dependence of the forward voltage drop in a junction biased at a constant current. Diodes are relatively easy to use and the instrumentation is fairly straightforward for these types of devices. Their large voltage signal allows thermoelectric voltages to be ignored in most cases. They have a large sensitivity, and can be used over a wide temperature range. An important feature of diodes

is their interchangeability. Magnetic fields strongly affect silicon diodes. Below 40 K they are extremely sensitive to magnetic fields and its orientation in the field [9]. The range of temperatures, in which the relationship between the voltage drop across a forward biased p-n junction diode and temperature at given current determines the extent of temperature response curve of the diode temperature sensor. The rate of the voltage drop variation with temperature characterizes its sensitivity. The extent of temperature response curve depends on bandgap width of semiconductor, excitation current, and doping impurity density in the diode substrate, whereas the sensitivity depends on the last two parameters [14]. By considering these points, selection of light emitting diodes (LEDs) as the cryogenic temperature sensor of choice is appropriate [15], [16].

**2.1 Sensor self-heating**

As mentioned above, the values of dielectric constants for most of the cryogenic fluids differ slightly from their cryogenic gaseous phase. This limits the application of capacitive sensors in cryogenic level sensing. Similarly, sensitivity issues limit the application of diode thermometry in two phase boundary detection at cryogenic temperatures.

Self heating method for liquid level detection using resistive sensors [17], [18] is also applicable to Silicon diodes. This method can be applied to LED based probes at cryogenic temperatures, as well.

**2.2 Current conveyor element**

An important part of the liquid cryogen level detection system described in this study is the electronic current conveyor element. The symbolic notation of a second generation current conveyor (CCII) is shown in Fig.1. This three terminal active element is characterized with the following equations [19], [20]:

$$V_x=V_y, \quad I_y=0, \quad I_z=I_x \quad (1)$$

It is the basic building block of a Current Feedback Amplifier (CFA) which can be thought as a cascade of a current conveyor and a unity gain voltage buffer circuit. (A well known CFA, AD 844 IC was first introduced in the market in early 1990 by Analog Devices Inc., as a first commercially available current conveyor with a buffer at the output [ 21], [22].

**3 The System and its components**

Principal circuit used for the liquid cryogen level sensing and measurement is given in Fig. 1. A current source drives LED diodes D1, D2, ..., Dn. A current conveyor element converts the voltage at its “y” terminal into a

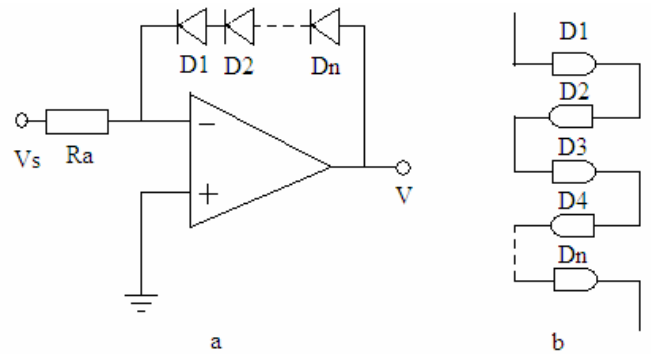

Fig. 2a. Experimental circuit used for cryogenic two phase boundary detection.

Fig. 2b. Physical LED placement on the level sensing probe. current output signal at its “z” terminal which is

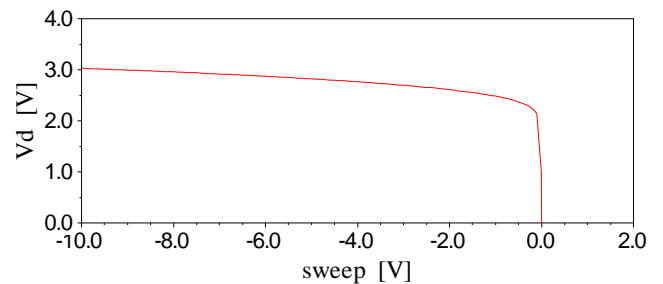

Fig. 3. Amplifier output voltage for a single LED 3mm dia. round true green (OSRAM LT 3333)

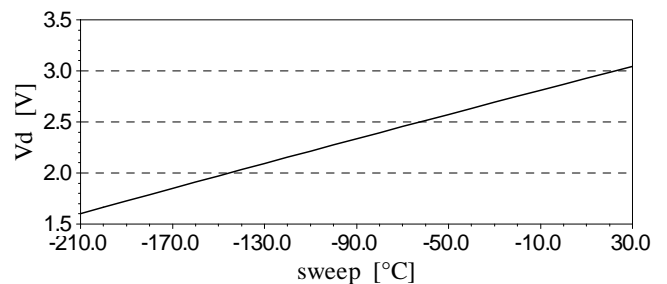

Fig. 4. Amplifier output voltage for a single LED (OSRAM LT 3333) as a function of temperature when the amplifier input voltage is at -10V. In the case of liquid nitrogen, Vd=1.6V at boil off temperature (-196°C).

displayed by an ammeter (CHY-21C). A resistor connected to x terminal of CCII determines the value of current depending upon the voltage measured over LEDs. It is realized by employing a commercially available CFA element (AD 844 Analog Devices Inc.)

and using its compensation terminal as the current output (z) terminal. Fig.2 shows the simplified op-amp based circuit used during experiments. The overall voltage observed over the series connected LEDs indicate if the LEDs are submerged into the liquid or exposed to gas, as this voltage has a higher value when any of the LEDs remains in the liquid cryogen. Therefore, maximum output current at the (z) output of current conveyor

(ammeter reading) implies that the voltage at (y) terminal of the CCH is at its largest value. This is the case when all LEDs are covered by liquid cryogen.

Physical placement of LEDs on the probe can be accomplished in several ways. In the case of cryopreservation in a liquid nitrogen dewar container, we fixed each LED on the outer walls of stainless steel canisters using flexible plastic cable binders. Fig.2 also demonstrates the manner in which LEDs are positioned on the probe (canister). It should be pointed out here that somehow horizontal placement of each LED increases the liquid-gas phase boundary detection sensitivity as compared to their vertical placement. We used OSRAM LT 3333 type round true green LEDs having 3mm diameter, reverse saturation current  $I_S=6.254\text{pA}$ , form factor  $N=5$ , equivalent series resistance of  $R_S=7.974\text{ Ohm}$  at nominal temperature.

#### 4 Results and Brief Discussion

Around the boil off temperatures of liquid nitrogen, the voltage drop over green LED was more temperature sensitive than red or yellow LEDs of the same 3mm round product series manufactured by OSRAM. Fig.3 displays amplifier output voltage for a single LED, while Fig.4 displays the amplifier output voltage for a single LED as a function of temperature when the amplifier input remains at a fixed voltage. At the constant current excitation, the forward voltage drop across the junction varies inversely as the temperature of the junction. The junction temperature is influenced by the ambient temperature and the heat sinking capability of the surroundings. The cryogen temperature at the boiling point of gas slightly above the liquid is almost at the same temperature. (We measured  $-194^\circ\text{C}$  at 1 cm above the nitrogen gas-liquid boundary). A LED does not alter its electro-thermal behavior in this surrounding because of these insignificant temperature variations, as expected in Fig.4. But, the gas and the liquid dissipation factors of the same cryogen may differ significantly, since the liquid is a better heat sink than the gaseous cryogen. At a constant current excitation, the temperature of the junction of a LED shows dramatic change between the two phases of the same cryogen; this temperature change is reflected as the voltage change across the LED. Typical voltage values observed were 2.2V and 4.2V at 12.5mA.

#### References:

[1]. W.Gross, O.Full, C.Schapper, "Level detector for a rotating liquid helium bath," *IEEE Trans.Magnetics*, Vol. MAG-17, No 5, 1981, pp. 2075-2077

[2]. A.Brown, MW Zemansky, HA Boorse, "A sensitive and reproducible thermometer in the range of 2 to 20 K" *Phys.Rev.*, Vol. 84, pp. 1050, 1951.

[3]. V.S. Egorov, "A liquid helium level indicator" *Cryogenics*, Vol. 10, , Aug. 1970, pp. 328

[4]. G.P.Shemonaev, V.I. Makankov, I.S. Sidorenko, "A floating level indicator for liquid helium", *Cryogenics*, Vol. 19, 1979 p. 140,.

[5]. G. Leemann, H.Jenny, H.R.Hidber, etal. "Design of a liquid-nitrogen level detector using high- $T_c$  superconductors" *Physica C*, Vol. 153, Part 2, Jun 1988 pp: 1427-1428, .

[6]. J. Talpe, G.Stolovitzky, V.Bekeris, "Cryogenic thermometry and level detection with common diodes" *Cryogenics*, Vol.27, no 12 Dec 1987 pp 693-695.

[7]. R. Blanpain, JP Delwiche, P. Mélon and F. Prouvreur, Short communication, *Vacuum*, Vol. 27, Issues 10-11, , 1977, pp. 617-618

[8]. E.Gmelin, K-H Greubel, M Knoop, M Thier "Cryogenic thermometry with common electronic diodes". *Cryogenics* Vol.30 (suppl.), 1990, pp.442-445.

[9]. C.J. Yeager, S.S. Courts "A review of cryogenic thermometry and common temperature sensors". *IEEE Sensors*, Vol.1, No.4, 2001, pp.352-360.

[10]. A.P. Rijpma, H.J.M. ter Brake, "Cryogenic thermometry with a common diode: Type BAS16", *Cryogenics* Vol.46, 2006, pp.68-69

[11]. N. S. Boltovets, V. V. Kholevchuk, R. V. Konakova, V. F. Mitin, E. F. Venger, "Ge-film resistance and Si-based diode temperature microsensors for cryogenic applications", *Sensors and Actuators A: Physical*, Vol. 92, Issues 1-3, Aug. 2001, pp:191-196.

[12]. Y. M. Shwarts, V. L. Borblik, N. R. Kulish, V. N. Sokolov, M. M. Shwarts, E. F. Venger, "Silicon diode temperature sensor without a kink of the response curve in cryogenic temperature region", *Sensors and Actuators A: Physical*, Vol. 76, Issues 1-3, August 1999, pp.107-111,.

[13]. M. Bose, S.B. Ota, "Study of forward characteristics of a cryogenic temperature sensor diode", *Review of Scientific Instruments* Vol 67 Issue: 12, Dec. 1996, pp: 4176-4178.

[14]. Y.M. Shwarts, VL Borblik, NR Kulish, E.F. Venger, V.N. Sokolov, "Limiting characteristics of diode temperature sensors" *Sensors and Actuators A-Physical*, Vol.86, 3, Nov 15 2000, pp.197-205 .

[15]. N.B. Manik, A. N. Basu and S. C. Mukherjee, "Characterisation of the photodetector and light emitting diode at above liquid nitrogen temperature", *Cryogenics*, Vol. 40, Issues 4-5, April-May 2000 pp. 341-344

[16]. J.D.N. Cheeke, C. Neron and A. Brunelle, "Gallium arsenide phosphide light-emitting diodes as general thermometers above 35 K", *Rev. Sci. Instrum.* Vol.54, , 1983, pp. 900-902.

[17]. A.U. Keskin, "A simple Analog Behavioral Model for NTC thermistors including selfheating effect", *Sensors and Actuators-A: Physical*, Vol. 118-2, Feb. 2005, pp. 244-247.

- [18]. A.U. Keskin, T.M. Yanar, "Steady-state solution of loaded thermistor problems using an electrical equivalent circuit model", *Measurement Science and Technology*, Vol. 15, (10) , 2004, pp. 2163-2169.
- [19]. J.A. Svoboda, L.Mcgory, S.Webb "Applications of a commercially available current conveyor." *Int. J. of Electronics*, Vol.70, 1991, pp 159-164.
- [20]. A.U. Keskin, U. Cam, "Insensitive High Output Impedance Minimum Configuration SITO type Current-Mode biquad using Dual-output Current Conveyors and grounded passive components", *AEU-Int. Journal of Electronics and Communications*, Vol.61, May, 2007, pp.343-344.
- [21]. *Amplifier reference manual*, Analog Devices Inc.,1992.
- [22]. A.U. Keskin, "Single CFA-based NICs with impedance scaling properties", *Journal of Circuits, Systems and Computers*, Vol. 14, No.2, April 2005, pp: 195-203.

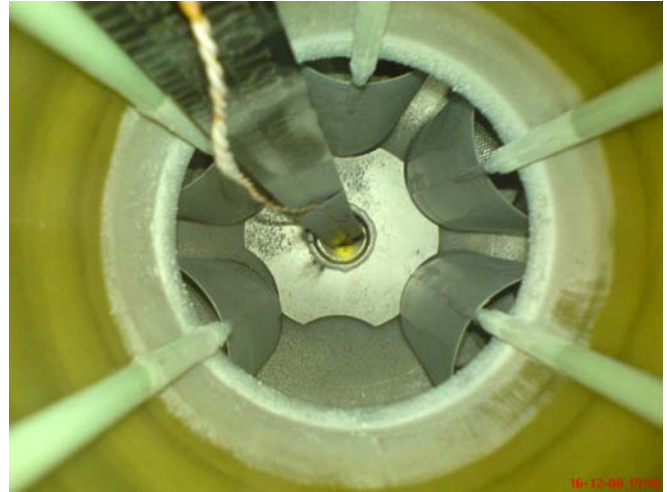

Fig.5. Top view of liquid nitrogen dewar flask (with a capacity of 19 liters) used during experiments. Six canisters are included in the unit (the one on the lower part of the picture was removed). At the center of the picture, there is a LED attached to a scaled dip stick and immersed in liquid nitrogen during tests.