

Numerical study of organic solar cell using Phthalocyanine/Perylene molecules

S. Boucekouf *, A. Marir, M. Benabbas-Marir.

Département d'électronique, Faculté des sciences de l'ingénieur, Université Mentouri, Constantine, Route d'Ain El Bey, 25000 Constantine, ALGERIE.

E-mail : *boucekoufs @ yahoo.fr*

ABSTRACT : -In this paper, we report on investigation uses a method of calculation the photocurrent delivered by the organic solar cell double-layer MPP/ZnPc applying the equations of continuities and the currents by analogy to the phenomena of loads transport according to the model of an heterojunction n/p. The principal generation of the photocurrent is localized in the active zone, a very fine area by contribution with the thicknesses of the donor and acceptor layers. Thus let us that the excitons dissociate only in the MPP/ZnPc interface, whereas the zone of absorption is considerably larger than the diffusion length.

The principal photovoltaic parameters of this structure are calculated by the simulation of equation I(V), under illumination AM_{1.5}. Insertion of the composite layer C60 and ZnPc in the interface of MPP and ZnPc makes it possible to improve the performances of the cell by an increase in the photocurrent of the value 2.6 mA/cm² to 5.3 mA/cm² and the conversion efficiency η from 0,72% to 1,49%.

We worked out a numerical model based on resolution of equations of continuities who gave results in good accordance with literature and which allowed, moreover a better control of performances of organic cells, for their improvement.

Key words:-organic solar cell, MPP/ZnPc structure, photocurrent, equation of continuity, the conversion efficiency η .

1. NOMENCLATURE

$D_n = \frac{\mu_n KT}{q}$	Diffusion constant of electrons.	$\Phi_i(\lambda)$ cm ⁻² by s ⁻¹ by unit of wavelength.	Flux of incidents photons by
$D_p = \frac{\mu_p KT}{q}$	Diffusion constant of holes.	R	Reflexion coefficient.
μ_n	Mobility of electrons.	α_1	Absorption coefficient in MPP.
μ_p	Mobility of holes.	x_b	Thickness of the ZnPc layer.
$\Delta n = n - n_e$	Density of excitons generated (electrons), n_e : density in balance.	L_p	Diffusion length of holes.
τ_n	Life time of minority carriers of area p (electrons).	Sp	Speed of recombination of the holes on the surface.
$\Delta p = p - p_e$	Density of generated holes, p_e : density in balance.	α_2	Absorption coefficient in ZnPc.
τ_p	Lifespan of minority carriers of area n (holes).	Sn	Speed of recombination of the electrons to the back contact.
G_n	Rate of electrons generation.	L_n	Diffusion length of the electrons
G_p	Rate of holes generation.	I	Current
		I_{CC}	Short-circuit current
		J	Current density
		V	Tension
		V_{OC}	Open circuit tension.
		FF	Fill factor.
		η	Conversion efficiency.

2. INTRODUCTION

Molecular electronics is a quickly developing field and the organic conducting materials were employed like active medium in the optoelectronic devices such as the luminescent diodes (LED), the field-effect transistors, sensors, lasers, the photodiodes and the solar cells. The organic solar cells drew a significant attention, because of their characteristic to be implemented by the promise of inexpensive manufacture and the large variety of functionality of organic materials [1, 2].

The performances of a solar cell depend on the thin layers between the electrodes. During two last decades, two types of organic solar cells were intensively studied: those built with a stacking of two organic layers (double-layer) and the others which use a built composite layer of a homogeneous mixture of two materials of the cell.

We propose in this investigation, contrary to the literature where the results are only experimental, a method of simulation based on the resolution of the equations of currents (continuities) for an organic solar heterostructure containing pigment methyl perylene (MPP) and the phthalocyanine of zinc (ZnPc) with like ITO/MPP/ZnPc/Au structure. These organic dyes have a good thermal stability, high absorption coefficients ($> 10^5 \text{cm}^{-1}$), and a sufficient electric conductivity, although the thickness of the useful layer of generation the carriers in organic cells is much finer than that of inorganic cells, the appreciable power conversion efficiency can be reached because of the high absorption coefficients. As p-conducting (ZnPc) and n-conducting (MPP) materials.

1. DESCRIPTION AND MECHANISMS OF GENERATION IN THE ORGANIC CELLS

The currently allowed photovoltaic process is the absorption of a photon by the active organic layer which generates an exciton (instead of the free carriers in the inorganic case) which diffuses through the material [3]. If the diffusion length of the exciton is sufficiently large to meet an internal field, the separation of the loads can take place. Hole and electron are then collected with the electrodes (respectively with the anode and cathode) according to the internal field of the cell. We go in what follows to describe the various architectures met in the organic cells photovoltaic and their own mechanisms.

2.1. The single-layer structure (Schottky)

The organic photovoltaic cells described as being of Schottky type with a conversion efficiency of 0,7% under AM_1 illumination, are presented in the form metal/organic/metal or ITO/organic/metal [4]. In this kind of structures, the properties of the cell are strongly related to the electrodes; moreover this structure presents a weak fill factor FF [5]. In order to increase the total conversion efficiency of a mono layer photovoltaic cell, a photovoltaic diode based on a Schottky structure was carried out with pentacene doped (iode or brome). The double-layer structure thus proves necessary for the improvement of the performances.

2.2. The double-layer structure (Heterojunction)

The structure of a double-layer cell is represented on (Fig. 1). To obtain an heterojunction of the type PN, the electrodes are selected so that one obtains ohmic contacts with organic films. The ITO is often used as semi-transparent electrode because, on the one hand it presents a transmittance of more than 85% in the visible one and on the other hand it presents an ohmic contact with certain conveying materials of holes (MPc, PTCDA...) [6]. The back electrode consists of metals like Al, Ag or of Mg:Ag alloy which make it possible to obtain an ohmic contact with materials of the type n [7].

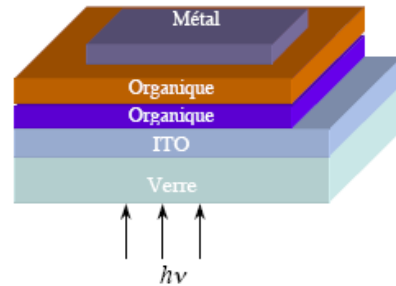

Fig. 1: Configuration of the structure of a double-layer photovoltaic cell [9].

2.2.1. Physical principles of organic solar cell

In the structures with heterojunction, the design and the collection of the photoinduced charges follow the following process, where the materials donor and acceptor develop an interface able to separate the carriers [8].

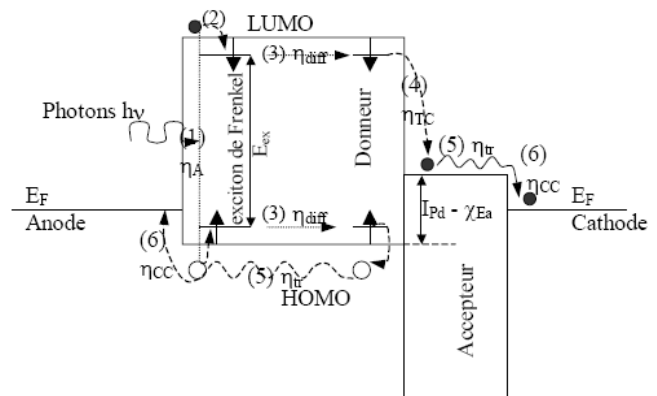

Fig. 2: mechanisms of the generation of carriers in an organic heterojunction [10].

(1) Photonic absorption.

(2) Generation of excitons

(3) **Diffusion of the exciton:** The exciton diffuses towards the interface between organic materials. If excitons are generated at a distance lower than $L_{D \text{ exc}}$ (called diffusion length of excitons), they can diffuse until the interface, so not they recombine.

(4) **Separation of the carriers:** The dissociation of the exciton is done with the interface between two materials. If the life-time of the excitation is sufficient so that the exciton meets an internal field, it appears a separation of the hole and electron.

- (5) Transport of the carriers towards the electrodes
 (6) Collect carriers with the electrodes.

2.2.2. Double-layer structures containing small molecules

More recent studies of a cell manufactured starting from perylene (MPP) and phthalocyanine (ZnPc) with as structure Au/MPP/ZnPc/Al [11] show that the generation of carriers appears only on the level of a very fine area of the active layer. The insertion of a layer made up of a mixture of C₆₀ and ZnPc (1:1) between ZnPc and MPP makes it possible to reach a conversion efficiency of 1, 05 % under AM_{1.5} [12].

2.2.3. Heterojunction containing polymer and C60

The first polymer organic solar cell is an architecture combining C₆₀ and one polymer like the PPP (polyparaphenylene) [13], the PPV (para phenylènevinylene) [14]. C₆₀ (Buckminsterfullerene) being a molecular organic compound comparable to an intrinsic semiconductor with gap direct [15, 16]. These cells present very weak conversion efficiency.

2.2.4. Heterojunction with only polymers

In the structures in interpenetrated networks the composite layer is a mixture of two polymers elements donors/acceptors, this technology improves the performances of the double-layer organic solar cells.

- Example of materials used:
 - Donor: the P3HT (poly (3-hexylthiophene), MEH-PPV (poly (2-methoxy-5(2' -ethyl-hexyloxy)-p-phenylenevinylene) [17], MDMO-PPV (poly (2-methoxy-5-dodecyloxy-p-phenylene vinylene) [18].
 - Acceptor: C₆₀, [6-6]-phenyl C₆₁ butyric acid methyl ester (PCBM), C₆₁ [19].
- Conversion efficiencies reached [20-22]:
 - 3,3% composite : MDMO-PPV/ PCBM (2002).
 - 5% composite : P3HT/PCBM (2005/2006).

3. SIMULATION OF THE DOUBLE-LAYER ORGANIC CELL MPP/ZnPc

In our study we interest in a doublelayer-structure containing small molecules described in paragraph 2.2.2.

The MPP/ZnPc heterojunction of the organic cell ITO/MPP/ZnPc/Au presented on (fig. 3), is a structure donor/acceptor. It allows the effective transfer of the photoelectrons since ZnPc which plays the role of donor towards the acceptor MPP. The two electrodes are made up of ITO and Au. The ITO often presents a semi-transparent electrode. The back electrode consists of Au. A layer made up of a mixture of C₆₀ and ZnPc (1:1), is inserted between the MPP and ZnPc to increase the number of dissociation sites of excitons. The cell that we studied is consisted of the structure: substrat/ITO (30nm)/MPP (20nm)/ZnPc (220)/Au (40nm) [23].

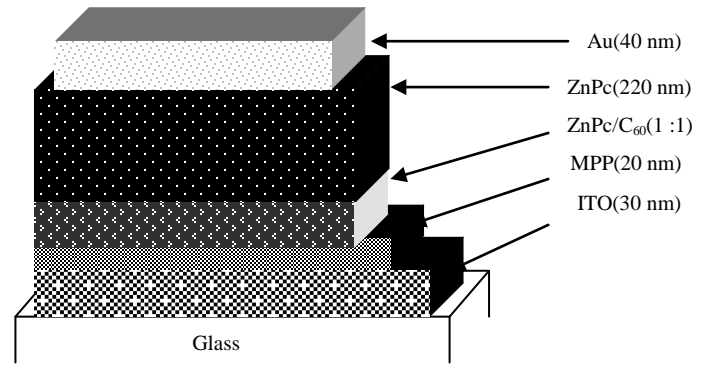

Fig. 3: Structure of the substrat/ITO/MPP/ZnPc/Au cell [23].

3.1 Calculation of MPP/ZnPc cell current

The absorption for the double-layer structure represented on (fig. 3) is carried out in the two layers. In this configuration only the excitons generated in the vicinity of the interface are effective for the generation of the photocurrent, this photocurrent is the sum of the current generated on the level of donor and the current in the acceptor.

For the simulation of the photocurrent of the cell one uses the geometry of (Fig. 4).

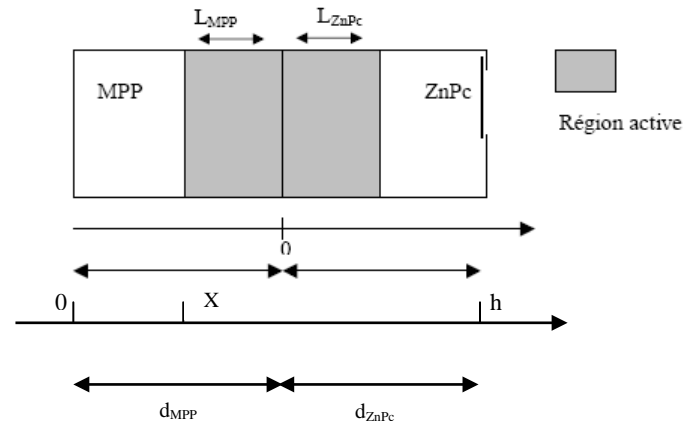

Fig. 4 : Geometrical model of the MPP/ZnPc structure [23].

Where D_{MPP} , D_{ZnPc} are dimensions of layers MPP and ZnPc respectively and L_{MPP} , L_{ZnPc} , diffusion lengths. For calculation takes some $L_{MPP}=1$ nm and $L_{ZnPc}=5$ nm.

The numerical resolution of the equations of continuities and the currents, by the iterative method allowed to determine the distribution of excitons along the cell and to deduce the equation which characterizes the current for each point of the cell.

$$\frac{\partial n}{\partial t} = G_n - \frac{\Delta n}{\tau_n} + \frac{1}{q} \text{div}(J_n) \quad (1)$$

$$\frac{\partial p}{\partial t} = G_p - \frac{\Delta p}{\tau_p} - \frac{1}{q} \text{div}(J_p) \quad (2)$$

- Equations of currents:

$$J_n = q\mu_n nE + \mu_n KT \frac{\partial n}{\partial x} \quad (3)$$

$$J_p = q\mu_p pE - \mu_p KT \frac{\partial p}{\partial x} \quad (4)$$

3.1.1 Calculation of the current in the MPP layer (n)

This layer gives us a photohole (Ip) expressed by the equation (7).

- Boundary conditions:

$$S_p \Delta_p = D_p \left. \frac{\partial \Delta p}{\partial x} \right|_{x=0} \quad (5)$$

$$\Delta p \Big|_{x=x_j} = 0 \quad (6)$$

$$J_p = \frac{q \alpha_1 L_p \Phi_i (1-R)}{(\alpha_1^2 L_p^2 - 1)} \left[\frac{\left(\frac{S_p L_p}{D_p} + \alpha_1 L_p \right) \exp(-\alpha_1 x_j) \left(\frac{S_p L_p}{D_p} \cosh\left(\frac{x_j}{L_p}\right) + \sinh\left(\frac{x_j}{L_p}\right) \right)}{\frac{S_p L_p}{D_p} \sinh\left(\frac{x_j}{L_p}\right) + \cosh\left(\frac{x_j}{L_p}\right)} \right] \quad (7)$$

$$L_p = L_{MPP} \quad (8)$$

3.1.2 Calculation of the current in ZnPc layer (p)

This zone presents the donor; it gives us a photoelectron (In).

- Boundary conditions:

$$S_n \Delta_n = D_n \left. \frac{\partial \Delta n}{\partial x} \right|_{x=h} \quad (9)$$

$$\Delta n \Big|_{x=x_j + L_{MPP} + L_{ZnPc}} = 0 \quad (10)$$

$$J_n = \frac{q \Phi_i (1-R) \exp(-\alpha_1 (x_j + L_{MPP})) \exp(-\alpha_2 L_{ZnPc}) \alpha_2 L_n}{(\alpha_2^2 L_n^2 - 1)} \left[\frac{\alpha_2 L_n - \frac{S_n L_n}{D_n} \left(\cosh\left(\frac{x_b}{L_n}\right) - \exp(-\alpha_2 x_b) \right) + \sinh\left(\frac{x_b}{L_n}\right) + \alpha_2 L_n \exp(-\alpha_2 x_b)}{\frac{S_n L_n}{D_n} \sinh\left(\frac{x_b}{L_n}\right) + \cosh\left(\frac{x_b}{L_n}\right)} \right] \quad (11)$$

$$L_n = L_{ZnPc} \quad (12)$$

$$x_b = h - (x_j + L_{MPP} + L_{ZnPc}). \quad (13)$$

3.1.3 The current in the active area (Ig)

The excitons generated in the active region (in the vicinity of the interface) are effective on the level of dissociation (production of the carriers), therefore, the photocurrent in this zone is:

$$J_g = q \Phi_i (1-R) \exp(-\alpha_1 x_j) \left[(1 - \exp(-\alpha_1 L_{MPP})) + \exp(-\alpha_1 L_{MPP}) (1 - \exp(-\alpha_2 L_{ZnPc})) \right] \quad (14)$$

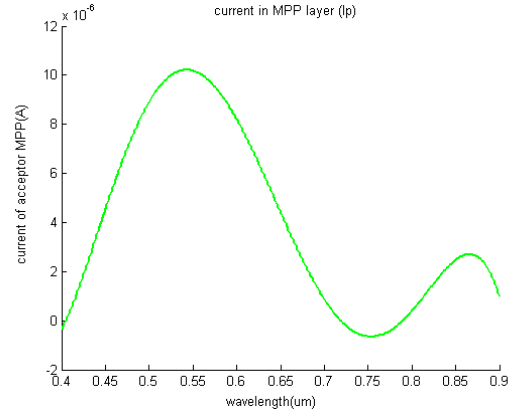

Fig. 5: Variation of the current of MPP layer according to the wavelength.

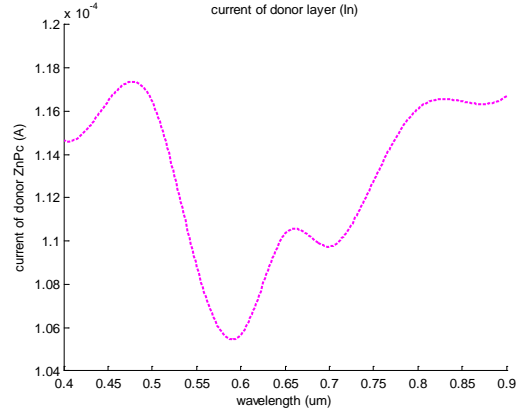

Fig. 6: Variation of the current of ZnPc layer according to the wavelength.

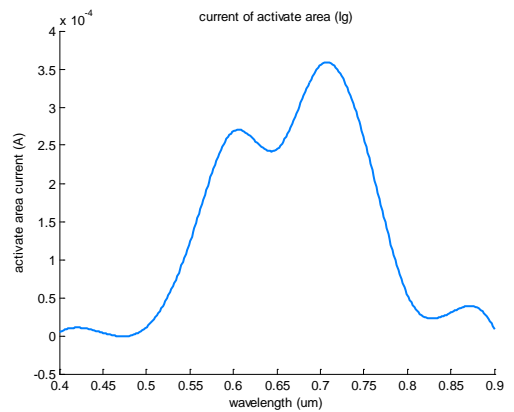

Fig. 7: Variation of the current of the activate area according to the wavelength.

(Fig. 7) shows interesting values of the photocurrent in the active area. This photocurrent is considerable compared with the photocurrents of layers MPP and ZnPc (Fig. 5) and (Fig. 6); it is about mA on a layer thickness of 6 nm. Comparing with the current in the ZnPc area, this last is comparable but the thickness of this layer is also larger (220 nm). The photocurrent of the active zone sweeps the interval of 500-800 nm and the maximum is around 700 nm.

These results affirm us that the principal generation of the photocurrent is localised in the active area, which presents a very fine area by contribution with the thicknesses of the donor layer and acceptor. Thus, the excitons generated in the active area (in the vicinity of the interface) are effective on the level of dissociation (production of photocurrent).

3.2. Characteristic I(V)

The equivalent circuit is given by (Fig. 8), where $R_s = R_{Au} + R_{ZnPc} + R_{ITO}$.

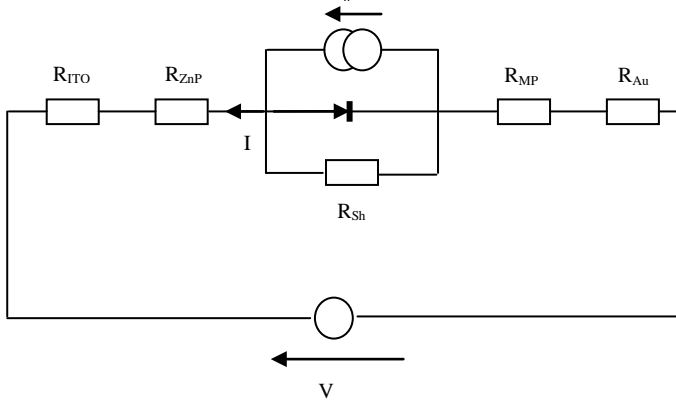

Fig. 8: Electric circuit of the MPP/ZnPc cell [23].

According to this equivalent circuit, we deduced the equation characteristic I (V) of the cell:

$$I(V) = I_{ph} - I_s \left[\exp\left(\frac{V + R_s I}{U_T}\right) - 1 \right] - \frac{V + R_s I}{R_{sh}} \quad (15)$$

The (Fig. 9) represent the I(V) characteristic, the conversion efficiency and the fill factor is given in (Table 1).

Table 1: Double-layer structural features MPP/ZnPc.

$I_{sc}(\text{mA}/\text{cm}^2)$	$V_{oc}(\text{mV})$	$\eta(\%)$	FF(%)
2.6	266.2	0.72	51.71

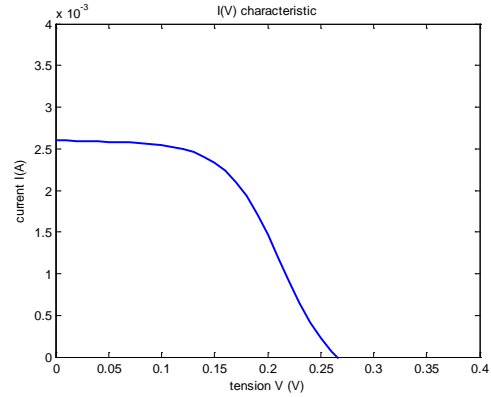

Fig.9: I(V) characteristic for the MPP/ZnPc structure.

3.2. 1. Insertion of the composite layer ZnPc/C60

For an improvement of the performances of the double-layer cell MPP/ZnPc, we need an increase thickness of the interfacial zone to resolve the problem of the recombinations due to the no dissociation of excitons create far from the interface of the heterojunction.

For this reason a layer made up of a mixture of C60 and ZnPc (1:1) is inserted between ZnPc and the MPP thickness of 30 nm.

The value of the calculated photocurrent increases the 2,6 mA to 5,3 mA [23]. The (Fig. 10) shows I(V) characteristic for this structure improved and a comparison with experimental results [23]. The (Table 2) summarize the characteristics of this structure.

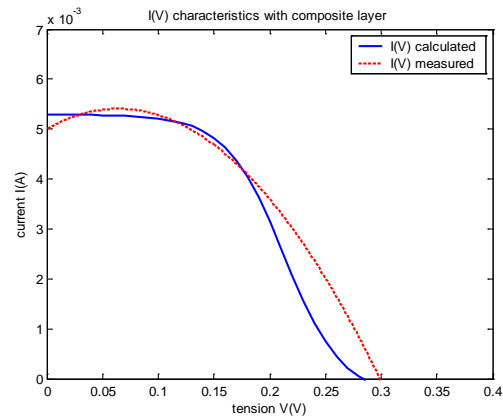

Fig. 10 : I(V) characteristic for the MPP/ZnPc structure contains the composite layer ZnPc/C₆₀(1:1).

Table 2: Performances of the double-layer structure MPP/ZnPc with the composite layer ZnPc/C₆₀.

$I_{sc}(\text{mA}/\text{cm}^2)$	$V_{co}(\text{mV})$	$\eta(\%)$	FF(%)
5.3	286.5	1.49	49.31

4. CONCLUSION

Until now the results obtained for organic solar cells either experimental or are based on statistical statements starting from the spectral answers of the cells. We worked out a numerical model based on the resolution of the equations of continuities who gave the results in good accordance with literature and which allowed, moreover a

better control of the performances of the organic cells, for their improvement.

5. REFERENCES

- [1] R.H. Friend, R.W. Gymer, A.B. Holmes, J.H. Burroughes, R.N. Marks, C. Taliani, D.D.C. Bradley, D.A. Dos Santos, J.L. Brédas, M. Lögdlund, W.R. Salaneck, *Nature*, 397, pp. 121, 1999.
- [2] A. J. Mozer, N.S. Sariciftci, 'Conjugated polymer photovoltaic devices and materials', *C. R. Chimie*, 9, pp. 568-577, 2006.
- [3] B.J.Land, R.P.Raffaella and all, *prog. Photovolt: Res.Appl*, 13, pp. 165-172, 2005.
- [4] A. K. Ghosh, T. J. Feng, *J. Appl. Phys*, 49, pp. 59-82, 1978.
- [5] Dhritiman Gupta, Sabyasachi Mukhopadhyay, K. S. Narayan, 'Fill factor in organic solar cells', *Solar Energy Materials & Solar Cells*, 2008.
- [6] C. W. Tang, 'Two-layer organic photovoltaic cell', *Appl. Phys. Lett*, 48, (2), pp. 183-185, 1986.
- [7] K. Seki, N. Hayashi, H. Oji, E. Ito, Y. Ouchi, H. Ishii, *Thin Solid Films*, 393, pp. 298, 2001.
- [8] S. Gunes, H. Neugebauer, N. S. Sariciftci, 'Conjugated Polymer-Based Organic Solar Cells', *Chem. Rev*, 107, (4), pp. 1324-1338, 2007.
- [9] M. Oukchmih, 'Les cellules photovoltaïques a base de matériaux organiques discotiques', Ph.D. Thesis, Laboratoire de Génie Electrique de Toulouse, Univ-Paul Sabatier, 2003.
- [10] B. Brousse, 'Réalisation et caractérisation de cellules photovoltaïques organiques obtenues par dépôt physique', Ph.D. Thesis, Ecole doctorale Sciences – Technologie – Santé, Faculté de Sciences et Technique de Limoges, Univ-Limoges, 2004.
- [11] J. Rostalski, D. Meissner, 'Photocurrent spectroscopy for the investigation of charge carrier generation and transport mechanism in organic p/n-junction solar cells', *Solar Energy Materials & Solar Cells*, 63, pp. 37-47, 2000.
- [12] J. Rostaski, D. Meissner, 'Monochromatic versus solar efficiencies of organic solar cells', *Sol. Energy Mater. Sol. Cells*, 61, pp. 87-95, 2000.
- [13] P. Peumans, A. Yakimov, S.R. Forrest, 'Small molecule weight organic thin-film photodetectors and solar cells', *J. Appl. Phys*, 93, (7), pp. 3693, 2003.
- [14] Halls, Pichler, Friend, Moratti, Holmes, 'Exciton dissociation at a PPV / C60 heterojunction', *Synthetic Metals*, 77, pp. 277-280, 1996.
- [15] Lee, Khabibullaev, Zakhidov, Morita, Yoshino, 'Photovoltaic properties of C60 / PPP heterojunction: molecular D – A photocell', *Synthetic Metals*, 71, pp. 2247-2248, 1995.
- [16] H. Jin, Y. Xianguo, 'Enhanced photovoltaic properties of polymer- fullerene bulk heterojunction solar cells by thermal annealing', *Solid state communication*, 142, pp. 181-184, 2007.
- [17] X. Meng, F. Teng, 'Electric field induced quenching of photoluminescence in the MEH-PPV: C₆₀', *Chemical physics lett*, 443, pp. 374-377, 2007.
- [18] Onada, and Tada: 'Photovoltaic effects of MDOPPV / PPy layer', *Thin Solid Films*, 393, pp. 284-290, 2001.
- [19] S. Bertho, I. Haeldermans and all, 'Influence of thermal ageing on the stability of polymer bulk heterojunction solar cells', *Solar Energy Materials & Solar Cells*, 91, pp. 385-389, 2007.
- [20] G. Li, V. Shrotriya, J. Huang, Y. Yao, T. Moriarty, K. Emery, Y. Yang, 'High-efficiency solution processable polymer photovoltaic cells by self-organization of polymer blends', *Nature Materials*, 4, pp. 864-868, 2005.
- [21] W. Ma, C. Yang, X. Gong, K. Lee, A. J. Heeger, 'Thermally Stable, Efficient Polymer Solar Cells with Nanoscale Control of the Interpenetrating Network Morphology', *Adv. Funct. Mater*, 15, (10), pp. 1617-1622, 2005.
- [22] M. Reyes-Reyes, K. Kim, J. Dewald, R. Lopez-Sandoval, A. Avadhanula, S. Curran, D. L. Carroll, 'Meso-Structure Formation for Enhanced Organic Cells', *Organic Letters*, 7, (26), pp. 5749-5752, 2005.
- [23] D. Meissner, J. Rostaski, 'Highly Efficient Molecular Organic Solar Cells'. in: *Proc. 16th European photovoltaic solar energy conf*, Glasgow, United Kindom, vol. 3, pp. 10-14, May 2000.