

99.99% Availability Realization of CATV Networks with Operation Maintenance and Administration Capability

XIN WANG, PENG ZHANG
School of Computer Engineering
Weifang University
Shandong 261061
China

Abstract: - Cable Television (CATV) networks have become the preferred transmission infrastructure to provide integrated high-quality services, and 99.99% availability is the specified ideal target of HFC networks. This paper focuses on the realization of 99.99% availability by operation, administration and maintenance (OAM). In order to ensure the network availability by OAM, the importance of reducing MTTR (Mean Time to Repair) is investigated, and three key influence factors are pointed out, which are the network design structure, the equipment MTBF, and the equipment MTTR. Following which, by comparatively studying three typical network models, the specific measures to improve network availability are developed. The key idea is to select reasonable network structure by combining available operation and maintenance. The numerical results clearly show that these measurements could achieve the availability goal of 99.99%.

Key-Words: -Network Dependability; Reliability; Availability; Maintainability; MTBF; MTTR

1 Introduction

Under the background of the integration of three networks, the business of radio and television is developing to the comprehensive information service provider [1]. Herein, in addition to the traditional broadcast television service, a series of value-added services are included, such as high-definition interactive TV [2], broadband data, VOIP (Voice over Internet Protocol), and so on [3, 4]. In such a situation, the users are putting forward higher requirements on the availability of the company's radio and television networks. Therefore, how to better improve network reliability to protect operational ability must be considered. In order to provide users with good quality, the cable TV network must achieve the level of operating requirement with 99.99% availability, i.e., one-year interrupt time is less than 53 minutes [5].

In recent years, lots of literatures have focused on how to improve the reliability and availability of cable TV networks. Some literatures have shown that the availability of CATV networks could be improved by changing network structure. For example, in [6] one fiber path protection switching mechanism was proposed by adopting multiple 1+1 protection paths, which was proved to be effective to enhance the survivability and quality of service of CATV networks. [7] showed that higher availability of cable TV networks could be achieved by adopting the hot standby router protocol with multilayer switches to prevent one switch (gateway) failure from

isolating an entire VLAN. [8] had comparative analysis between centralized and P2P networks in terms of providing VoD service to cable television networks, which demonstrated that the main parameters of the traffic models were useful for planning the network structure to maintain its availability. Similar literatures could be founded in [9], [10], [11].

In addition to changing the network structure to pursue high availability, more of literatures had focused on investigating the reliability and availability of specific cable TV networks, as well as searching for the solutions to realize high availability. For instance, [12] analyzed the transformation loss rate of information packet for the Bi-directional cable TV network with double queues and single server. [13] provided one new viewpoint to deal with the problems in the implementation of hybrid TV via clouding computing. [14] analyzed the combination of DVB-C and IPTV networks in an unique architecture by considering some crucial elements like QoS and QoE in different distribution scenarios. [15] had an analysis of CATV access network by adopting EPON+HiNOC. Moreover, from [11] and [16], we knew that a common management system was really significant for a multiprotocol distributed system.

From the existing research results, it had clearly shown that the reliability and availability of CATV networks were mainly affected by the network failure and recovery, which were enslaved to the network architecture, the network management and maintenance mechanism. As far

as we have known, this area is still a hot research spot with many issues remaining unresolved [17].

In this paper, we will focus on how to improve the device's MTTR (Mean Time to Repair) by operation management. Firstly, the reliability of cable network is analyzed, from which three major key factors influencing the availability are indicated, which are the design of network structure, the equipment of MTBF (Mean Time Between Failures) and the equipment of MTTR. And then some suggestions about improving network availability are provided.

2 Availability analysis of CATV networks

2.1 The main indicators [18]

1) λ : The average failure rate, which commonly uses "times / year" as the unit.

2) MTBF: Mean Time between Failures (i.e., the average life expectancy).

3) MTTR: Mean Time to Repair, which is the average time of failure elimination.

4) A: Availability.

5) U: Unavailability, $U = 1 - A$.

2.2 The simplified calculation method of CATV network availability

In the actual calculation, MTTR and MTBF often take "hours" and "years" for the unit, respectively [19]. And then, the average interruption time caused by the s th device is calculated as (unit: minutes / year):

$$T_s = \frac{MTTR_s}{MTBF_s} \times 60 \quad (1)$$

The unavailability of the s th device is (herein, $525600 = 60 \times 24 \times 365$ accounts for the total minutes of a year.)

$$U_s = \frac{T_s}{525600} \quad (2)$$

Thus, the availability of the s th device is

$$A_s = 1 - U_s = 1 - \frac{T_s}{525600} \quad (3)$$

3 The key factors affecting the network availability

At first, we must clearly distinguish two different concepts, reliability and availability. In many cases, the difference between them is often misinterpreted. High availability and high reliability are usually complementary [5]. However, they are really not

interchangeable. Specially, availability is determined by the system reliability and the recovery time after the failure. If a system runs continuously for a long time (such as 10 years), the system failure is inevitable. Furthermore, if a failure occurs really, the key point is how to restore the system as quickly as possible. So, the first important point is to use reliable equipments and system design to pursuit long-time normal working. On the other hand, once a failure occurs, the system could return to the normal working as soon as possible. As can be seen, the key factors affecting the network availability mainly include

- 1) The design of network structure,
- 2) The MTBF of network devices,
- 3) The MTTR of network devices.

3.1 The design of network structure

There are two basic models in terms of network structure, which are serial and parallel.

- 1) The unavailability of N serial units is

$$U_n = 1 - (A_1 \times A_2 \times \dots \times A_N) \quad (4)$$

In which $A_i, i = 1, 2, \dots, N$ denotes the availability of the i th unit.

- 2) The unavailability N parallel units is

$$U_n = U_1 \times U_2 \times \dots \times U_N \quad (5)$$

In which $U_i, i = 1, 2, \dots, N$ denotes the unavailability of the i th unit.

As shown in (4), the availability of a serial link is the product of the availability of all units. So adding additional unit will reduce the reliability, and increase the interruption probability of the entire serial link. However, for the parallel link as shown in (5), its unavailability is the product of the unavailability of its parallel units. So by increasing the parallel levels, the whole unavailability could be reduced, and the whole reliability could be increased. Clearly, the network structure will directly affect its reliability. Therefore, reliability model analysis is often done in the initial stage of network construction, and the network constructions with high reliability will improve the network availability.

3.2 The MTBF of network devices

MTBF is a widely used term to measure the network reliability, which is the Mean Time between Failures, i.e., the average life expectancy [20]. As the embodiment of the reliability of a product, the bigger the MTBF value, the higher reliability of the product, the lower probability of failure, and the fewer number of network interruption. So MTBF directly affects the network availability.

3.3 The MTTR of network devices

MTTR is the estimated time to recover system from failure [21]. This may includes time to diagnose the problem, and the actual maintenance time of the system. MTTR affects availability, but does not affect reliability. In short, if the system recovering time from failure is longer, i.e., the larger the MTTR, the system usability will become worse.

4 The main measures to guarantee the availability of cable networks

Here, by selecting a medium-sized city with CATV HFC networks, the system availability is analyzed. And hereby the main strategies to guarantee the availability of cable networks could be achieved based on the analysis of three key factors.

4.1 The influence of the network design on the network availability

First assuming that the same equipment specifications, i.e., the same MTBF and MTTR are hold, the following two design models respect to different network structures are analyzed and the network availability is calculated correspondingly.

4.1.1 Model 1

As shown in fig. 1, the network structure is a star-star-tree without the network equipment management system.

Optical node is placed in the wild. Cable network has two levels of power amplifier, and all links are set without redundancy backup.

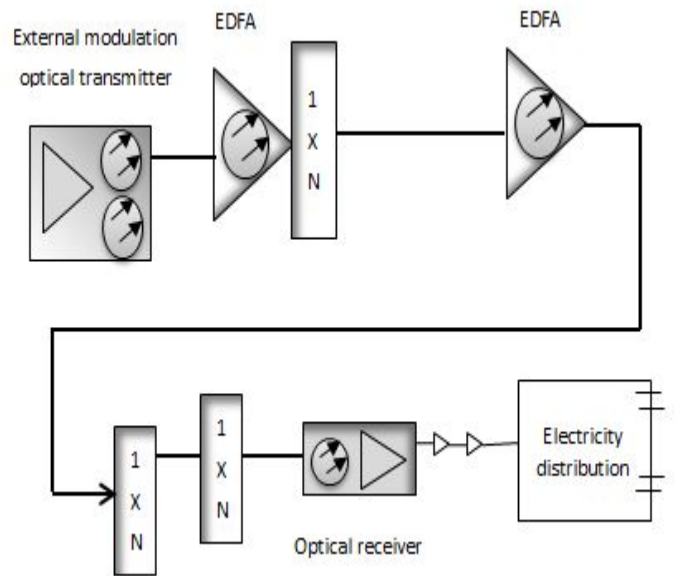

Fig. 1. 1550 optical fiber transmission system without backup

Corresponding to fig. 1, the simplified reliability model is redrawn as fig. 2.

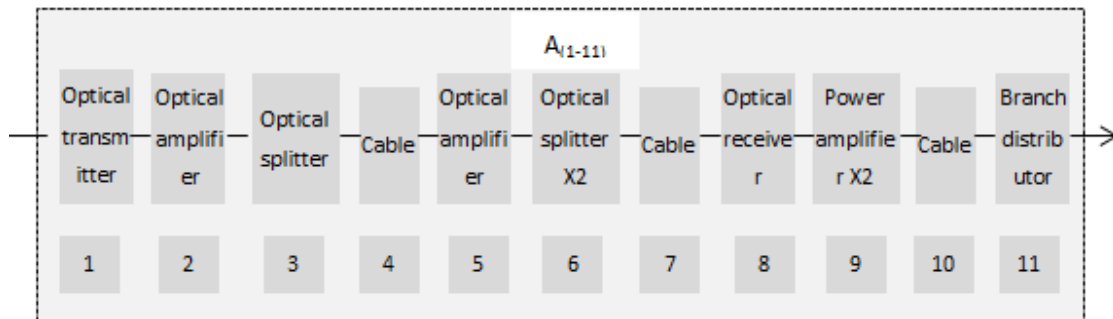

Fig. 2. Simplified reliability model of 1550 optical fiber transmission system without backup

According to fig. 2, MTBF and MTR of all equipments are given in table 1.

Table 1. MTBF and MTR of all equipments

Equipment	MTBF(year)	MTR(hour)	U	A
Optical transmitter	20	4	0.00002283	0.99997717
Optical switch	30	4	0.00001522	0.99998478
Optical amplifier	20	4	0.00002283	0.99997717
Optical splitter	35	4	0.00001305	0.99998695
Cable	35	12	0.00003914	0.99996086
Optical receiver	10	12	0.00013699	0.99986301
Coaxial cable	15	12	0.00009132	0.99990868
Power amplifier	10	12	0.00013699	0.99986301

Branch distributor	15	12	0.00009132	0.99990868
--------------------	----	----	------------	------------

So we have

$$A_{(1-11)} = A_1 \times A_2 \times A_3 \times A_4 \times A_5 \times A_6 \times A_7 \times A_8 \times A_9 \times A_{10} \times A_{11} = 0.999220747.$$

Here, the system availability of this serial structure is the product of all equipments' availability, and the result is approximately equal to 0.99922. Correspondingly, the annual interruption time is about 410 minutes.

4.1.2 Model 2

As shown in fig. 3, optical transmitter and optical amplifier is 1:1 hot backup. Furthermore, the network structure adopts ring-star-tree structure to realize the trunk route redundancy backup, as well as to implement FTTB (Fiber to the Building) and passive coaxial cable network.

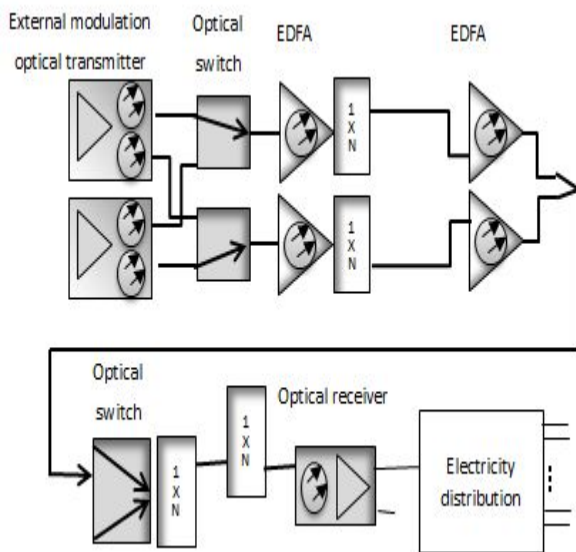

Fig. 3. FTTB 1550nm optical transmission system with equipment hot backup and routing redundancy

Corresponding to fig. 3, the simplified reliability model is shown as fig 4.

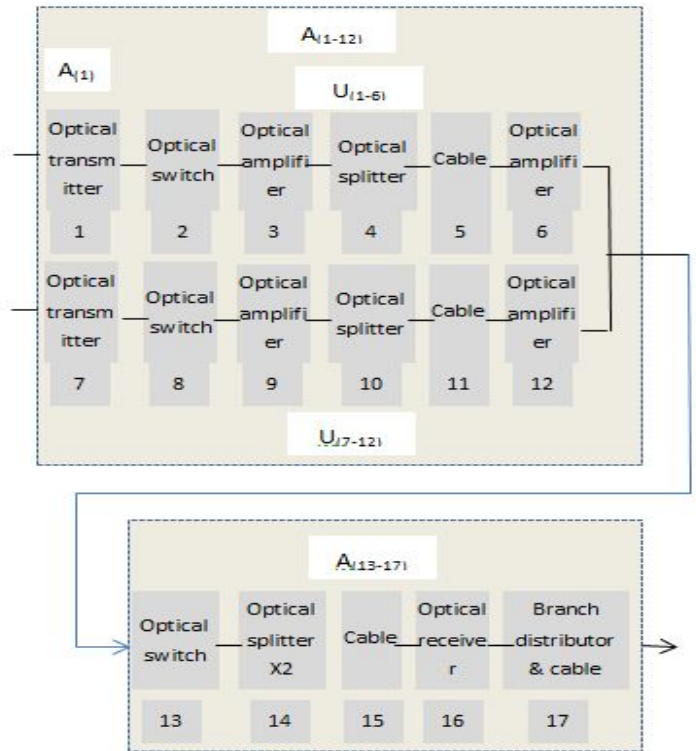

Fig. 4. Simplified reliability model of FTTB 1550nm optical transmission system

According to fig 4, MTBF and MTR of all equipments are given in table 2.

Table 2. MTBF and MTR of all equipment

Equipment	MTBF(year)	MTTR(hour)	U	A
Optical transmitter	20	4	0.00002283	0.99997717
Optical switch	30	4	0.00001522	0.99998478
Optical amplifier	20	4	0.00002283	0.99997717
Optical splitter	35	4	0.00001305	0.99998695
Cable	35	12	0.00003914	0.99996086
Optical receiver	10	12	0.00013699	0.99986301
Coaxial cable	15	12	0.00009132	0.99990868
Branch distributor	15	12	0.00009132	0.99990868

So we have

$$A_{(1)} = 1 - U_{(1)} = 1 - U_1 \times U_7 = 0.999999999$$

$$U_{(1-6)} = 1 - A_{(1-6)} = 1 - A_{(1)} \times A_2 \times A_3 \times A_4 \times A_5 \times A_6 = 0.000113064$$

$$U_{(7-12)} = 1 - A_{(7-12)} = 1 - A_{(1)} \times A_8 \times A_9 \times A_{10} \times A_{11} \times A_{12} = 0.000113064$$

$$A_{(1-12)} = 1 - U_{(1-6)} \times U_{(7-12)} = 0.999999987$$

$$A_{(13-17)} = A_{13} \times A_{14} \times A_{15} \times A_{16} \times A_{17} = 0.999599974$$

$$A_{(1-17)} = A_{(1-12)} \times A_{(13-17)} = 0.999599962$$

It should be noted that for the parallel structure combining with serial structure, we should first calculate the system availability of the parallel parts, and then calculate the system availability of the serial parts. As calculated above, the final system availability of fig. 3 is approximately equal to 0.999599, and hereby the annual interruption time is about 211 minutes.

4.1.3 Results Comparison

Table 3. Results comparison of two different models

	Model 1	Model 2
Annual interruption time	410	211
Availability of system	0.999220747	0.999599962

As demonstrated in table 3, by comparing the calculation results of the above two different models, it can be seen that the design of network structure is really significant on their availability. In order to improve the network availability, the optimization of the network design structure is necessary.

4.2 Measures to optimize network design structure

1) Cable route must adopt the standby redundant protection

As a main transmission medium in the traditional HFC networks with the serial structure, the cable is the weakest link, which directly affects the system availability of the whole transmission network [22]. And the longer transmission distance is more likely to be influenced by the uncertainty destruction of environment, which will cause the system interruption. Through the main standby redundant protection, the parallel structure can greatly improve the availability of the whole transmission network.

2) Key equipments must be hot backup

Equipments, as the smallest unit of the whole system, usually don't directly affect the system availability. Through hot backup for equipments to realize the parallel transmission, the reliability of each equipment unit could be improved, and hereby the whole network availability is promoted.

3) For the distribution networks using FTTH, try to reduce the bearing capacity of the optical nodes.

In the traditional HFC networks, the weakest link is the cable network [23]. Firstly, the cable network is based on serial structure design. Secondly, optical nodes cover wide users, which results in a large number of power amplifiers and serial equipments. Thirdly, active cable cover is easily affected by the external factors such as the damage of lightning. So the distribution network should be designed by using FTTH to realize the replacement of copper cables with optical fibers and passive coverage. Furthermore, by reducing the serial units and active equipments to improve the reliability of the cable network, the entire network's availability could be promoted.

4.3 The influence of MTBF and MTTR on the network availability

Although the optimizing of the network structure can improve the network availability, it is still difficult to achieve the availability goal of 99.99% only through the optimization of the structure design [1]. In order to realize higher network availability, another effective method is to reduce the network's MTTR. The essence of MTTR is the event of failure, and hereby to reduce MTTR means to restore the failure equipments and businesses back to normal as soon as possible, i.e., try to reduce the interrupt time.

As we know, MTBF is only determined by the device itself, while MTTR is affected by the whole network. So the availability optimizing measures should pay more attention to optimizing the network's MTTR. On the basis of the foregoing model 2, a new model 3 is presented. The two models have the same network design structure and equipment specification. However, they adopt different

MTTR for calculations. The detailed analysis and optimizing measures of MTTR are given as follows.

4.3.1 Model 3

Compared with Model 2, Model 3 adds the network device management system. And hereby the MTTR of all

equipments could be optimized and the whole network’s availability could achieve great promotion. Model 3 has the same reliability model as Model 2, as shown in fig. 4. However, their MTTR calculation is different, and the comparisons between them are given in table 4.

Table 4. MTTR comparisons between Model 2 and Model 3

Same	Same	Model2	Model3	Model2	Model3	Model2	Model3
Equipment	MTBF (year)	MTTR (hour)	MTTR (hour)	U	U	A	A
Optical transmitter	20	4	2	0.00002283	0.00001142	0.99997717	0.99998858
Optical switch	30	4	2	0.00001522	0.00000761	0.99998478	0.99999239
Optical amplifier	20	4	2	0.00002283	0.00001142	0.99997717	0.99998858
Optical splitter	35	4	2	0.00001305	0.00000652	0.99998695	0.99999348
Cable	35	12	4	0.00003914	0.00001305	0.99996086	0.99998695
Optical receiver	10	12	2	0.00013699	0.00002283	0.99986301	0.99997717
Coaxial cable	15	12	2	0.00009132	0.00001522	0.99990868	0.99998478
Branch distributor	15	12	2	0.00009132	0.00001522	0.99990868	0.99998478

Corresponding to Model 3, the calculation results are

$$A_{(1)} = 1 - U_{(1)} = 1 - U_1 \times U_7 = 0.999999999$$

$$U_{(1-6)} = 1 - A_{(1-6)} = 1 - A_{(1)} \times A_2 \times A_3 \times A_4 \times A_5 \times A_6 = 0.00005001$$

$$U_{(7-12)} = 1 - A_{(7-12)} = 1 - A_{(1)} \times A_8 \times A_9 \times A_{10} \times A_{11} \times A_{12} = 0.00005001$$

$$A_{(1-12)} = 1 - U_{(1-6)} \times U_{(7-12)} = 0.999999997$$

$$A_{(13-17)} = A_{13} \times A_{14} \times A_{15} \times A_{16} \times A_{17} = 0.999913028$$

$$A_{(1-17)} = A_{(1-12)} \times A_{(13-17)} = 0.999913025$$

4.3.2 Results analysis

As shown in Table 5, the final system availability of Model 3 is improved to 0.999913, and the annual

interruption time is about 46 minutes. While the system availability of Model 2 is only 0.999599, and the annual interruption time is about 211 minutes.

Table 5. Results Comparison between Model 2 and Model 3

	Model 2	Model 3
Annual interruption time	211	46
Availability of system	0.999599962	0.999913025

The comparison results clearly show that the network availability could be greatly increased by improving the MTTR of equipments. Via combining the optimization of the network structure with the MTTR improvement the availability goal of 99.99% could be achieved finally. The following question is what kind of measures can be taken to optimize the MTTR of equipments.

4.4 Optimizing MTTR with the help of operation and maintenance of NMS

As above analyzed, if you want to improve equipment MTTR, you must increase the speed of fault location and

fault handling response [24]. In order to improve these two speeds, it is necessary to use the real integration operation and maintenance management of NMS (network management system). The question is what kind of NMS can be a NMS combining operation and maintenance management. In a word, this kind of NMS must support the entire network operation, and help operation staff to improve the whole operational efficiency [11].

Specially, network manager can be associated with the call centers synchronously. Once fault occurs, the network manager can automatically determine the equipment problems or link problems, as well as the severity of the

fault. Call center immediately explains the link's problems, generates the fault handling suggestions and sends to the operation and maintenance staff. According to the fault location and treatment suggestions, maintenance personnel directly locate the fault point, and feedback the time that the troubleshooting is needed. Call center again explain to the users. Therefore, the new NMS with both operation and maintenance must have the following key features.

1) Graphical topology

Table 6. Cost time of fault location and fault handling response after optimization (MTFR)

Equipment	Model 2 MTTR(hour)	Model 3 MTTR(hour)	Fault handling	The main factor of MTTR time
Optical transmitter	4	2	Replace the equipment	Fault location, corresponding speed
Optical switch	4	2	Replace the equipment	Fault location, corresponding speed
Optical amplifier	4	2	Replace the equipment	Fault location, corresponding speed
Optical splitter	4	2	Replace the equipment	Fault location, corresponding speed
Cable	12	4	On-site maintenance	Fault location, corresponding speed, Maintenance time
Optical receiver	12	2	Replace the equipment	Fault location, corresponding speed
Coaxial cable	12	2	On-site maintenance	Fault location, corresponding speed
Branch distributor	12	2	Replace the equipment	Fault location, corresponding speed

From Table 6 we can see that after using network management system with operation and maintenance, the equipment MTTR could be effectively improved. Just as demonstrated in the calculation results of model 3, with the optimized NMS the network availability could achieve the goal of 99.99%.

5 Conclusions

This paper discusses the key factors influencing the availability of cable television networks. The analysis has demonstrated that there are three key influence factors, which are the network design structure, the equipment MTBF, and the equipment MTTR. Furthermore, by analyzing and comparing three typical network models, the specific measures to improve network availability are

References:

- [1] J. Zhuang, Availability Realization of CATV Networks by Network Management System with Operation Maintenance and Administration Capability, *2011 International Coverage and Transmission Conference*, 2011, pp. 474-483.
- [2] Y. Hakamada, N. Nakamura, T. Kurakake, T. Kusakabe and K. Oyamada, UHDTV (8K)

- 2) Fault analysis system
- 3) Strong compatibility
- 4) Interface to the user's Boss system (call center system)

Let's take a look at the network management system after optimization, and table 6 demonstrates the cost time of fault location and fault handling response of equipment MTFR after optimization.

provided. The results show that the available operation and maintenance of NMS is really necessary for cable television networks to improve the network availability. It also clearly shows that with help of the optimizing NMS the network could achieve the availability goal of 99.99%.

6 Acknowledgement

This research was partly supported by the National Natural Science Foundation of China (No. 61471269), the Doctoral Scientific Research Fund Project of Weifang University of China (No. 2014BS12) and Weifang Science and Technology Development Plan Project (No. 2014GX021).

- distribution technology and field trial on cable television networks, *ITE Transactions on Media Technology and Applications*, 2(1), 2014, pp. 2-7.
- [3] T. L. Dong, *Optical fiber communication and optical fiber information network*, Tsinghua University Press, 2006.

- [4] Y. X. Zhu, *Modern communications technology (Third Edition)*, Electronic Industry Press, 2011.
- [5] J. Zhuang, B. Hu, R. J. Lin, How to build highly reliable CATV networks with availability of 99.99%, *Shanghai Luster Teraband Photonics Co.,Ltd.*, 2010.
- [6] F. H. Shih, J. R. Lai, W. P. Chen and L. K. Wang, Four-path multiple ∞ -shaped fiber protection mechanism for cable television networks, *Opt. Eng.* Mar 04, 2015, 54(3).
- [7] Y. h. Zhang and W. Z. Ma, The design of cable television IP access network based on hot standby router protocol, *2012 International Conference on Image Analysis and Signal Processing (IASP)*, 2012, pp. 1-4.
- [8] L. Jordanova, J. Nenkov and D. Dobrev, Comparative analysis between centralized and P2P system traffic in terms of providing VoD service to cable television network subscribers, *International Journal of Computer Science and Network Security*, 13(9), Sept. 2013, pp. 29-35.
- [9] D. Trstensky, L. Schwartz, and V. Hottmar, Structural reliability of interactive cable television, *Advances in Military Technology*, vol.1, No.1, Jun. 2010.
- [10] Z. B. Wang, K. S. Yu and X. X. Zhou, Study on the New Topology of Power Electronic Transformer, *WSEAS Transactions on Circuits and Systems*, Issue 11, Volume 10, November 2011, pp.371-377.
- [11] J. Sabat and J. R. Millar, Operations and maintenance architecture for multiprotocol distributed system, *US Patent 8762510*, 2014.
- [12] H. W. Ding, Y. W. Yang, J. Guo, Y. Wang, Y. Y. Guo, Q. L. Liu, The analysis of the loss rate of information packet of double queue single server in Bi-directional cable TV network, *Applied Mechanics and Materials*, vol 665, Oct. 2014, pp. 674-678.
- [13] X. Zheng, F. Xiong, and Y. N. Dai, The technical exploration of implementing hybrid TV with cloud computing in radio and TV industry, *2014 IEEE Computing, Communications and IT Applications Conference (ComComAp)*, Oct. 2014, pp. 229-233.
- [14] R. Arsinte and E. Lupu, Analysis of architectures for audio-video services distribution in hybrid IPTV/DVB-C networks, *2014 IEEE International Conference on Automation, Quality and Testing, Robotics*, 2014, pp. 1-6.
- [15] Q. Qian, Y. f. Ou, B. Li and J. F. Cui, Analysis of CATV Access Network Technology EPON+HiNOC, *Video Engineering*, 18, 2012.
- [16] J. M. Gao, Design and application of CATV network management system based on SNMP, *University of Electronic Science and technology*, 2008.
- [17] Ch. Y. Liu, Development and reflection of cable triple play, *China Digital Cable TV*, Jan. 2015.
- [18] GB/T20030-2005: *Specification for HFC network equipment management system*.
- [19] W. C. Yang and W. T. Huang, An Enhanced Load Transfer Scheme for Power Distribution Systems Connected with Distributed Generation Sources, *WSEAS Transactions on Circuits and Systems*, Issue 4, Volume 10, April 2011, pp136-138.
- [20] W. Ji, J. Liu and W. J. Zhuang, The evolution of HFC networks, *Optical Communication Technology*, 2007, pp. 37-38.
- [21] Y. Tao, *Network systems management and control*, Posts and Telecom Press, 2007.
- [22] X. B. Zhang and J. Zhang, *Cable network management and operations*, Electronic Industry Press, 2001.
- [23] Q. L. Hu, *Network management and maintenance*, Tsinghua University Press, Beijing Jiaotong University Press, 2007.
- [24] Y. P. Fan, Research and implementation of network fault management system based on SNMP, *Henan University*, 2007.